

ANNALI DELLA
SCUOLA NORMALE SUPERIORE DI PISA
Classe di Scienze

H. ATTOUCH

G. BUTTAZZO

Homogenization of reinforced periodic one-codimensional structures

Annali della Scuola Normale Superiore di Pisa, Classe di Scienze 4^e série, tome 14,
n° 3 (1987), p. 465-484

http://www.numdam.org/item?id=ASNSP_1987_4_14_3_465_0

© Scuola Normale Superiore, Pisa, 1987, tous droits réservés.

L'accès aux archives de la revue « Annali della Scuola Normale Superiore di Pisa, Classe di Scienze » (<http://www.sns.it/it/edizioni/riviste/annaliscienze/>) implique l'accord avec les conditions générales d'utilisation (<http://www.numdam.org/conditions>). Toute utilisation commerciale ou impression systématique est constitutive d'une infraction pénale. Toute copie ou impression de ce fichier doit contenir la présente mention de copyright.

NUMDAM

Article numérisé dans le cadre du programme
Numérisation de documents anciens mathématiques
<http://www.numdam.org/>

Homogenization of Reinforced Periodic One-Codimensional Structures

H. ATTOUCH - G. BUTTAZZO

1. Introduction

Periodic reinforced structures play an important role in modern technology: stratified, alveolar, fibred reinforced materials are frequently used in civil engineering, aeronautics...

Such structures are characterized by the geometrical properties of the reinforced zone (especially its "codimension") and by *three parameters*:

- ε the period of the structure,
- r the "thickness" of the reinforced zone,
- λ the physical parameter (conductivity, elasticity coefficient) of the reinforced zone.

Typically, for such structures, ε is small with respect to the size of the global structure, r is small with respect to ε , and λ is large with respect to the surrounding (non reinforced) material.

The macroscopic behaviour of such material is described by means of the asymptotic analysis (called homogenization and reinforcement) of the constitutive (which we take second order linear elliptic) equations as

$$\varepsilon \longrightarrow 0, \quad r \longrightarrow 0 \quad \text{with} \quad \frac{r}{\varepsilon} \longrightarrow 0, \quad \text{and} \quad \lambda \longrightarrow +\infty.$$

We focus our attention here on the case of one-codimensional reinforced structures (stratified, alveolar...), the case of fibres in dim 3 (two codimensional structures) being much more involved (cf. Attouch - Buttazzo [22], paper in preparation), one reason being that a one-codimensional manifold has a strictly positive capacity while a two-codimensional one has zero capacity!

For such one-codimensional reinforced structures we show the existence of a critical ratio $\frac{\lambda r}{\varepsilon}$, and compute, depending on the limit of $\frac{\lambda r}{\varepsilon}$, the limit homogenized-reinforced material. (We stress the fact that our results hold without any restriction on the shape of the reinforced zone).

Pervenuto alla Redazione il 5 novembre 1986.

This asymptotic analysis is performed by means of Γ -convergence method, the solutions being expressed as minimizers of the corresponding energy functionals. By the way, convergence of the energies and of the momentum (dual solutions) are also obtained. The effective coefficients are explicitly computed (in the last section) for some structures of particular interest, the reinforced-homogenized formula (5.1) being proved efficient and flexible for numerical computation.

Let us finally mention some recent related works where some aspects of the above problem are considered: Chabi [11] (stratified structure), Cioranescu-Saint Jean Paulin [12] (first $\varepsilon \rightarrow 0$, then $(r, \lambda) \rightarrow (0, +\infty)$ for structures with particular symmetries), Bakhvalov-Panasenko [3] (formal asymptotic expansions), and Caillerie [9].

2. Statement of the result

Let Ω be a bounded open subset of \mathbb{R}^n with a Lipschitz boundary; we want to study the conductivity problem in Ω (with a given charge density) when many thin highly conductive layers are periodically distributed in it.

More precisely, let $Y = [0, 1]^n$ be the unit cube in \mathbb{R}^n , and let $S \subset Y$ be a smooth (or piecewise smooth) $n - 1$ dimensional surface.

For every $\varepsilon > 0$, $r > 0$, $\lambda > 0$ set (see figure 1)

$$S_\varepsilon = \{\varepsilon(x + y) : x \in S, y \in \mathbb{Z}^n\}$$

$$S_{\varepsilon,r} = \{x \in \mathbb{R}^n : \text{dist}(x, S_\varepsilon) < r/2\}$$

$$a_{\varepsilon,r,\lambda}(x) = \begin{cases} \lambda & \text{if } x \in S_{\varepsilon,r} \\ 1 & \text{if } x \in \mathbb{R}^n - S_{\varepsilon,r} \end{cases}$$

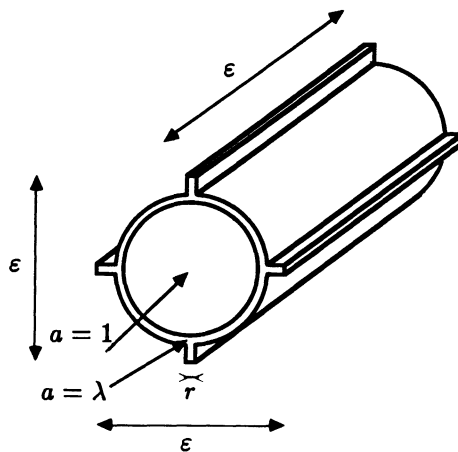

Fig. 1

and consider the functional defined on $H^1(\Omega)$ by

$$(2.1) \quad F_{\epsilon,r,\lambda}(u) = \int_{\Omega} a_{\epsilon,r,\lambda}(x) |Du|^2 dx.$$

The functional $F_{\epsilon,r,\lambda}(u)$ represents the electrostatical energy of the body Ω (subjected to the potential u) when the periodically distributed layers $S_{\epsilon,r}$ are supposed to have a conductivity coefficient λ .

Given a charge density $g \in L^2(\Omega)$, we want to study the asymptotic behaviour (when $\epsilon \rightarrow 0$, $r \rightarrow 0$, $\lambda \rightarrow +\infty$) of the solutions $u_{\epsilon,r,\lambda}$ of the variational problems

$$\min \left\{ F_{\epsilon,r,\lambda}(u) + \int_{\Omega} g(x)u dx : u \in H_0^1(\Omega) \right\}$$

and to characterize the limit of $u_{\epsilon,r,\lambda}$ as the solution \bar{u} of a new variational problem

$$\min \left\{ F(u) + \int_{\Omega} g(x)u dx : u \in H_0^1(\Omega) \right\}.$$

The problem is then reduced to the identification of the Γ -limit F of the functionals $F_{\epsilon,r,\lambda}$ defined in (2.1). Indeed, by well-known results (see Proposition 2.1) this immediately implies the convergence of $u_{\epsilon,r,\lambda}$ to \bar{u} . For simplicity, in the following we shall often omit the limit variable in the expressions \lim , $\lim \inf$, $\lim \sup$.

For the reader's convenience we recall the definitions of Γ -limits (further information can be found for instance in Attouch [1], Buttazzo [5], Buttazzo-Dal Maso [6], Carbone-Sbordone [10], De Giorgi [14], De Giorgi-Franzoni [15] and in references quoted there).

Let X be a metric space and let $F_{\epsilon} : X \rightarrow \bar{\mathbb{R}} (\epsilon > 0)$ be a family of functionals. For any $x \in X$ we define

$$(2.2) \quad \Gamma(X) \lim \inf_{\epsilon \rightarrow 0^+} F_{\epsilon}(x) = \inf \{ \lim \inf_{\epsilon \rightarrow 0^+} F_{\epsilon}(x_{\epsilon}) : x_{\epsilon} \rightarrow x \text{ in } X \}$$

$$(2.3) \quad \Gamma(X) \lim \sup_{\epsilon \rightarrow 0^+} F_{\epsilon}(x) = \inf \{ \lim \sup_{\epsilon \rightarrow 0^+} F_{\epsilon}(x_{\epsilon}) : x_{\epsilon} \rightarrow x \text{ in } X \}.$$

Finally, we say that F_{ϵ} $\Gamma(X)$ -converges at the point $x \in X$ if

$$\Gamma(X) \lim \inf F_{\epsilon}(x) = \Gamma(X) \lim \sup F_{\epsilon}(x),$$

and this common value is denoted by $\Gamma(X) \lim F_{\epsilon}(x)$. It is possible to prove that the infima in (2.2), (2.3) are actually minima, so that F_{ϵ} $\Gamma(X)$ -converges to F at x if and only if

$$(2.4) \quad \begin{cases} \text{i) } \forall x_{\epsilon} \rightarrow x & F(x) \leq \lim \inf F_{\epsilon}(x_{\epsilon}) \\ \text{ii) } \exists x_{\epsilon} \rightarrow x & F(x) = \lim F_{\epsilon}(x_{\epsilon}). \end{cases}$$

The link between Γ -convergence and Calculus of Variations is given by the following proposition (see references quoted above).

PROPOSITION 2.1. *Assume that F_ε $\Gamma(X)$ -converges to F at any point $x \in X$ and that F_ε are equi-coercive, that is for any $t \in \mathbb{R}$ there exists a compact subset K_t of X such that*

$$\forall \varepsilon > 0 \quad \{x \in X : F_\varepsilon(x) \leq t\} \subseteq K_t.$$

Then we have:

- i) *the functional F admits a minimum on X and $\min_X F = \lim [\inf_X F_\varepsilon]$;*
- ii) *if $x_\varepsilon \rightarrow \bar{x}$ is such that $\lim F_\varepsilon(x_\varepsilon) = \lim [\inf_X F_\varepsilon]$, then \bar{x} is a minimum point for F on X ;*
- iii) *if $G : X \rightarrow \mathbb{R}$ is continuous, then $G + F = \Gamma(X) \lim[G + F_\varepsilon]$.*

Now, we come back to our functionals $F_{\varepsilon,r,\lambda}$ defined in (2.1). The problem we are interested in, is the characterization of the $\Gamma(L^2(\Omega))$ -limit of $F_{\varepsilon,r,\lambda}$ when the three parameters ε, r, λ tend to $0, 0, +\infty$ simultaneously. This Γ -limit actually depends on the way the three parameters go to $0, 0, +\infty$ respectively. In fact, our result is the following, where H^{n-1} is the $n-1$ dimensional Hausdorff measure, W is the space of all functions in $H_{loc}^1(\mathbb{R}^n)$ which are Y -periodic, and $D_\tau v$ denotes the tangential derivative of v on S

$$D_\tau v = Dv - \nu \langle Dv, \nu \rangle \quad (\nu \text{ is the unit normal vector to } S).$$

THEOREM 2.2. *Assume that $\frac{\lambda r}{\varepsilon} \rightarrow k \geq 0$. Then there exists a positive definite, symmetric quadratic form on \mathbb{R}^n*

$$f(z) = \sum_{i,j=1}^n \alpha_{ij} z_i z_j \quad (\alpha_{ij} = \alpha_{ji} \text{ constant coefficients})$$

such that:

- i) *for every $u \in H^1(\Omega)$ there exists $\Gamma(L^2(\Omega)) \lim F_{\varepsilon,r,\lambda}(u) = F(u)$;*
- ii) *we have $F(u) = \int_\Omega f(Du) dx$ for every $u \in H^1(\Omega)$;*
- iii) *the following representation formula for f holds:*

$$(2.5) \quad f(z) = \min \left\{ \int_Y |Dv|^2 dx + k \int_S |D_\tau v|^2 dH^{n-1} : v - \langle z, \cdot \rangle \in W \right\}.$$

REMARK 2.3. From Theorem 2.2 and Proposition 2.1 it follows that for every $g \in L^2(\Omega)$ and $\alpha > 0$ the solutions $u_{\epsilon,r,\lambda}$ of the problems

$$\min \left\{ F_{\epsilon,r,\lambda}(u) + \alpha \int_{\Omega} u^2 dx + \int_{\Omega} g(x)u dx : u \in H^1(\Omega) \right\}.$$

converge in $L^2(\Omega)$ to the solution \bar{u} of

$$\min \left\{ F(u) + \alpha \int_{\Omega} u^2 dx + \int_{\Omega} g(x)u dx : u \in H^1(\Omega) \right\}.$$

By well-known Γ -convergence arguments (see for instance Attouch [1], Buttazzo-Dal Maso [6], Carbone-Sbordone [10], Marcellini [18]) we can prove that the same conclusion holds if $u_{\epsilon,r,\lambda}$ and \bar{u} are respectively solutions of

$$\begin{aligned} & \min \left\{ F_{\epsilon,r,\lambda}(u) + \int_{\Omega} g(x)u dx : u \in H_0^1(\Omega) \right\} \\ & \min \left\{ F(u) + \int_{\Omega} g(x)u dx : u \in H_0^1(\Omega) \right\}. \end{aligned}$$

The $\Gamma(L^2(\Omega))$ -limit of the functionals $F_{\epsilon,r,\lambda}$ has been studied, in different situations, by several authors. For example, when λ is fixed and r goes to zero with the same order as ϵ with $\frac{r}{\epsilon} \rightarrow \frac{k}{\lambda}$, then the limit analysis is classic (see for instance Bensoussan-Lions-Papanicolaou [4], Marcellini [18]) and the limit functional is

$$(2.6) \quad F_{0,0,\lambda}(u) = \int_{\Omega} f_{\lambda}(Du) dx$$

where the quadratic form f_{λ} is given by the so-called homogenization formula

$$f_{\lambda}(z) = \min \left\{ \int_y a_{1,k/\lambda,\lambda}(x) |Dv|^2 dx : v - \langle z, \cdot \rangle \in W \right\}.$$

On the contrary, if ϵ is fixed and r goes to zero with the same order as $1/\lambda$ with $\lambda r \rightarrow \epsilon k$, then the limits functional is (see for instance Attouch [1], Carbone-Sbordone [10], Sanchez-Palencia [19])

$$(2.7) \quad F_{\epsilon,0,\infty}(u) = \int_{\Omega} |Du|^2 dx + \epsilon k \int_{\Omega \cap S_{\epsilon}} |D_{\tau}u|^2 dH^{n-1}.$$

Our Theorem 2.2 permits to calculate the Γ -limits of the functionals $F_{0,0,\lambda}$ and $F_{\epsilon,0,\infty}$ defined in (2.6), (2.7) respectively; in fact, the following result holds (see also Cioranescu-Saint Jean Paulin [12]).

THEOREM 2.4. *Indicating by F the $\Gamma(L^2(\Omega))$ -limit of $F_{\epsilon,r,\lambda}$ when $\epsilon \rightarrow 0$, $r \rightarrow 0$, $\lambda \rightarrow +\infty$ with $\frac{\lambda r}{\epsilon} \rightarrow k$, we have:*

- i) $F_{0,0,\lambda}$ $\Gamma(L^2(\Omega))$ -converges to F (as $\lambda \rightarrow +\infty$);
- ii) $F_{\epsilon,0,\infty}$ $\Gamma(L^2(\Omega))$ -converges to F (as $\epsilon \rightarrow 0$).

PROOF. Since all functionals we consider are $L^2(\Omega)$ -equicoercive, the $\Gamma(L^2(\Omega))$ -convergence is induced by a compact metric d (see Attouch [1], De Giorgi [13,14], De Giorgi-Franzoni [15]).

By the classic homogenization result, for every $\lambda > 0$ we can find a number $\epsilon \leq \frac{1}{\lambda}$ such that setting $r = \frac{k\epsilon}{\lambda}$ we have

$$d(F_{\epsilon,r,\lambda}, F_{0,0,\lambda}) \leq \frac{1}{\lambda}.$$

Theorem 2.2 implies that $F_{\epsilon,r,\lambda}$ $\Gamma(L^2(\Omega))$ -converges to F (as $\lambda \rightarrow +\infty$), hence, by the triangle inequality

$$\limsup d(F, F_{0,0,\lambda}) \leq \limsup \left[d(F, F_{\epsilon,r,\lambda}) + \frac{1}{\lambda} \right] = 0,$$

and this proves i). The proof of ii) is analogous. ■

3. Proof of the result

In all this section we denote by $w - H^1(\Omega)$ the weak topology of $H^1(\Omega)$, and by c an arbitrary positive constant; the quantities ϵ, r, λ are supposed to tend to $0, 0, +\infty$ respectively, with $\frac{\lambda r}{\epsilon} \rightarrow k \in [0, +\infty[$. When there is no ambiguity we shall write w_ϵ instead of $w_{\epsilon,r,\lambda}$, u_ϵ instead of $u_{\epsilon,r,\lambda}$... The following lemma will be useful.

LEMMA 3.1. *Let $w_\epsilon \rightarrow 0$ in $w - H^1(\Omega)$; then $\lim \frac{\epsilon}{r} \int_{\Omega \cap S_{\epsilon,r}} |w_\epsilon|^2 dx = 0$.*

PROOF. For simplicity, denote by η the quantity r/ϵ , and let u be a smooth function. For every $y \in Y \cap S_{1,\eta}$ we have

$$|u(y)|^2 = \left| u(\sigma) + \int_{\sigma}^y \langle Du(\sigma + t\nu), \nu \rangle dt \right|^2 \leq 2 \left[|u(\sigma)|^2 + \eta \int_{\sigma}^y |Du|^2(\sigma + t\nu) dt \right]$$

where σ is the point on S of least distance from y , and ν is the unit normal vector to S at the point σ . By integration we get

$$(3.1) \quad \int_{Y \cap S_{1,\eta}} u^2 \, dy \leq c \left[\eta \int_S u^2 \, dH^{n-1} + \eta^2 \int_{Y \cap S_{1,\eta}} |Du|^2 \, dy \right].$$

The continuous imbedding of $H^1(Y)$ into $L^2(S)$ gives

$$\int_S u^2 \, dH^{n-1} \leq c \left[\int_Y u^2 \, dy + \int_Y |Du|^2 \, dy \right],$$

so that, by (3.1)

$$\int_{Y \cap S_{1,\eta}} u^2 \, dy \leq c\eta \left[\int_Y u^2 \, dy + \int_Y |Du|^2 \, dy \right].$$

Setting $v(y) = u(y/\varepsilon)$ and performing the change of variables $x = \varepsilon y$ we obtain

$$(3.2) \quad \int_{\varepsilon Y \cap S_{\varepsilon,r}} v^2 \, dx \leq c \frac{r}{\varepsilon} \left[\int_{\varepsilon Y} v^2 \, dx + \varepsilon^2 \int_{\varepsilon Y} |Dv|^2 \, dx \right]$$

where the constant c depends only on S . Formula (3.2) holds for every cell $\varepsilon(Y + y)$ with $y \in \mathbb{Z}^n$, so that taking the sum on all cells contained in Ω one has for every smooth function v

$$(3.3) \quad \frac{\varepsilon}{r} \int_{\Omega \cap S_{\varepsilon,r}} v^2 \, dx \leq c \left[\int_{\Omega} v^2 \, dx + \varepsilon^2 \int_{\Omega} |Dv|^2 \, dx \right].$$

Formula (3.3) can be extended by a density argument to all functions $v \in H^1(\Omega)$, so that if $w_\varepsilon \rightarrow 0$ in $w - H^1(\Omega)$ we get

$$\limsup \frac{\varepsilon}{r} \int_{\Omega \cap S_{\varepsilon,r}} w_\varepsilon^2 \, dx \leq c \limsup \left[\int_{\Omega} w_\varepsilon^2 \, dx + \varepsilon^2 \int_{\Omega} |Dw_\varepsilon|^2 \, dx \right] = 0. \blacksquare$$

Denote by \mathcal{A} the class of all open subsets of Ω . For every $A \in \mathcal{A}$ and every $u \in H^1(A)$ set

$$F_{\varepsilon,r,\lambda}(u, A) = \int_A a_{\varepsilon,r,\lambda}(x) |Du|^2 \, dx$$

$$F^-(u, A) = \Gamma(L^2(A)) \liminf F_{\varepsilon,r,\lambda}(u, A)$$

$$F^+(u, A) = \Gamma(L^2(A)) \limsup F_{\varepsilon,r,\lambda}(u, A).$$

LEMMA 3.2. *There exists a constant $c > 0$ such that for every $A \in \mathcal{A}$ and $u \in H^1(A)$*

$$F^+(u, A) \leq (1 + kc) \int_A |Du(x)|^2 dx.$$

PROOF. Since $F^+(\cdot, A)$ is $L^2(A)$ -lower semicontinuous and $u \rightarrow \int_A |Du|^2 dx$ is $H^1(A)$ -continuous, we may reduce ourselves to prove the assertion when u is a smooth function. In this case set

$$\begin{aligned} \varphi_{\varepsilon, r}(x) &= \left[1 - \frac{\text{dist}(x, S_{\varepsilon, r})}{r} \right]^+ \\ u_{\varepsilon, r}(x) &= (1 - \varphi_{\varepsilon, r}(x))u(x) + \varphi_{\varepsilon, r}(x)u(\sigma(x)) \end{aligned}$$

where $\sigma(x)$ is the point on S_{ε} of least distance from x . Then

$$\begin{aligned} (3.4) \quad F^+(u, A) &\leq \limsup F_{\varepsilon, r, \lambda}(u_{\varepsilon, r}, A) \\ &\leq \limsup \left[\int_{A \setminus S_{\varepsilon, 3r}} |Du|^2 dx + \lambda \int_{A \cap S_{\varepsilon, r}} |D_{\tau} u|^2 dx \right] \\ &\quad + \limsup \int_{A \cap S_{\varepsilon, 3r}} |u(\sigma) - u(x)|^2 |D\varphi_{\varepsilon, r}|^2 dx \\ &\leq \int_A |Du|^2 dx + k \cdot \limsup \frac{\varepsilon}{r} \int_{A \cap S_{\varepsilon, r}} |D_{\tau} u(\sigma)|^2 dx \\ &\quad + \limsup \frac{c}{r^2} \int_{A \cap S_{\varepsilon, 3r}} |u(\sigma) - u(x)|^2 dx. \end{aligned}$$

Moreover, since u is smooth (take u Lipschitz with constant L)

$$\begin{aligned} (3.5) \quad \frac{1}{r^2} \int_{A \cap S_{\varepsilon, 3r}} |u(\sigma) - u(x)|^2 dx &\leq \frac{1}{r^2} L^2 \cdot (3r)^2 \cdot \int_{A \cap S_{\varepsilon, 3r}} dx \\ &\leq 9L^2 \frac{\text{meas } A}{\varepsilon^N} \cdot H_{N-1}(S) \cdot \varepsilon^{N-1} 3r \\ &\leq C \frac{r}{\varepsilon} = \frac{Ck}{\lambda} \end{aligned}$$

which tends to zero.

Let us finally consider the term $\int_{A \cap S_{\varepsilon, r}} |D_{\tau} u(\sigma)|^2 dx$ in (3.4).

Assuming $u \in C^2$ we first obtain

$$\frac{\varepsilon}{r} \int_{A \cap S_{\varepsilon, r}} |D_{\tau} u(\sigma)|^2 dx \leq \frac{\varepsilon}{r} \int_{A \cap S_{\varepsilon, r}} |D_{\tau} u(x)|^2 dx + \frac{c\varepsilon}{r} \int_{A \cap S_{\varepsilon, r}} dx.$$

Hence

$$\limsup \frac{\varepsilon}{r} \int_{A \cap S_{\varepsilon,r}} |D_\tau u(\sigma)|^2 dx \leq \limsup \frac{\varepsilon}{r} \int_{A \cap S_{\varepsilon,r}} |Du(x)|^2 dx.$$

Applying inequality (3.3) of Lemma 3.1 to $v = Du$ we obtain

$$\frac{\varepsilon}{r} \int_{A \cap S_{\varepsilon,r}} |Du(x)|^2 dx \leq c \left[\int_A |Du(x)|^2 dx + \varepsilon^2 \int_A |D^2 u|^2 dx \right].$$

Combining these two last inequalities

$$(3.6) \quad \limsup \frac{\varepsilon}{r} \int_{A \cap S_{\varepsilon,r}} |D_\tau u(\sigma)|^2 dx \leq c \int_A |Du|^2 dx.$$

Thus, by (3.4), (3.5), (3.6) we obtain

$$F^+(u, A) \leq (1 + ck) \int_A |Du|^2 dx. \quad \blacksquare$$

REMARK 3.3. It follows in a straight way from Lemma 3.2 that, when $k = 0$,

$$\int_A |Du|^2 \leq F^-(u, A) \leq F^+(u, A) \leq \int_A |Du|^2,$$

$$\Gamma(L^2(A)) \lim F_{\varepsilon,r,\lambda}(u, A) = \int_A |Du|^2$$

that is, the highly conductive layers have a negligible macroscopic effect. This result can also be obtained (see Attouch [1], Carbone-Sbordone [10]) by noticing that in that case

$$a_{\varepsilon,r,\lambda} \rightarrow 1 \text{ in } L^p(\Omega) \text{ for any } 1 \leq p < +\infty.$$

Indeed $\int_\Omega a_{\varepsilon,r,\lambda}(x) dx \simeq |\Omega|(1 + H_{N-1}(S) \cdot \frac{\lambda r}{\varepsilon})$, the case $\frac{\lambda r}{\varepsilon} \rightarrow k \in]0, +\infty[$ corresponds to the following property:

“the sequence $a_{\varepsilon,r,\lambda}$ is bounded in $L^1(\Omega)$, but not equiintegrable”.

Let us now examine the properties of $F^+(u, \cdot)$ and $F^-(u, \cdot)$.

LEMMA 3.4. Let $A, B \in \mathcal{A}$ be disjoint, and let $u \in H^1(A \cup B)$. Then

$$F^-(u, A \cup B) \geq F^-(u, A) + F^-(u, B).$$

PROOF. It follows straightforward from the definition of $F^-(u, \cdot)$ \blacksquare

LEMMA 3.5. *Let $A, B, C \in \mathcal{A}$ with $C \subset\subset A \cup B$, and let $u \in H^1(A \cup B)$. Then*

$$F^+(u, C) \leq F^+(u, A) + F^+(u, B).$$

PROOF. Let $u_\varepsilon \rightarrow u$ in $L^2(A)$ and $v_\varepsilon \rightarrow u$ in $L^2(B)$ be such that

$$(3.7) \quad \begin{cases} F^+(u, A) = \limsup F_{\varepsilon, r, \lambda}(u_\varepsilon, A) \\ F^+(u, B) = \limsup F_{\varepsilon, r, \lambda}(v_\varepsilon, B). \end{cases}$$

Since we may assume that $F^+(u, A)$ and $F^+(u, B)$ are finite, we have

$$(3.8) \quad u_\varepsilon \rightarrow u \text{ in } w - H^1(A) \text{ and } v_\varepsilon \rightarrow u \text{ in } w - H^1(B).$$

Let $\varphi \in C_0^\infty(A)$ be such that $0 \leq \varphi \leq 1$ and $\varphi = 1$ in a neighbourhood of $C - B$, and define

$$w_\varepsilon = \varphi u_\varepsilon + (1 - \varphi)v_\varepsilon.$$

Then $w_\varepsilon \rightarrow u$ in $L^2(C)$ and we have for every $t \in]0, 1[$

$$\begin{aligned} |Dw_\varepsilon|^2 &= \left| t\varphi \frac{Du_\varepsilon}{t} + t(1 - \varphi) \frac{Dv_\varepsilon}{t} + (1 - t) \frac{u_\varepsilon - v_\varepsilon}{1 - t} D\varphi \right|^2 \\ &\leq \frac{\varphi}{t} |Du_\varepsilon|^2 + \frac{1 - \varphi}{t} |Dv_\varepsilon|^2 + \frac{|D\varphi|^2}{1 - t} |u_\varepsilon - v_\varepsilon|^2 \end{aligned}$$

so that

$$\begin{aligned} (3.9) \quad &F^+(u, C) \leq \limsup F_{\varepsilon, r, \lambda}(w_\varepsilon, C) \\ &\leq \limsup \left[\frac{1}{t} \int_A |Du_\varepsilon|^2 dx + \frac{1}{t} \int_B |Dv_\varepsilon|^2 dx + \frac{1}{1 - t} \int_{A \cap B} |D\varphi|^2 |u_\varepsilon - v_\varepsilon|^2 dx \right. \\ &\quad \left. + \frac{\lambda}{t} \left\{ \int_{A \cap S_{\varepsilon, r}} |Du_\varepsilon|^2 dx + \int_{B \cap S_{\varepsilon, r}} |Dv_\varepsilon|^2 dx \right\} + \frac{\lambda}{1 - t} \int_{A \cap B \cap S_{\varepsilon, r}} |D\varphi|^2 |u_\varepsilon - v_\varepsilon|^2 dx \right] \\ &\leq \frac{1}{t} F^+(u, A) + \frac{1}{t} F^+(u, B) + \frac{c(\varphi)}{1 - t} \limsup \left[\int_{A \cap B} |u_\varepsilon - v_\varepsilon|^2 dx \right. \\ &\quad \left. + k \frac{\varepsilon}{r} \int_{A \cap B \cap S_{\varepsilon, r}} |u_\varepsilon - v_\varepsilon|^2 dx \right] \end{aligned}$$

where $c(\varphi)$ is a constant depending on φ . Since u_ε and v_ε converge to u in $L^2(A \cap B)$ we have

$$\lim \int_{A \cap B} |u_\varepsilon - v_\varepsilon|^2 dx = 0;$$

moreover, taking into account (3.8), Lemma 3.1 yields

$$\lim_{\frac{\varepsilon}{r}} \int_{A \cap B \cap S_{\varepsilon,r}} |u_\varepsilon - v_\varepsilon|^2 dx = 0.$$

Therefore, using (3.7), (3.9) we get

$$F^+(u, C) \leq \frac{1}{t} [F^+(u, A) + F^+(u, B)]$$

and, since $t \in]0, 1[$ was arbitrary, the proof is achieved. ■

REMARK 3.6. In a similar way we can prove that for every $A, B \in \mathcal{A}$ with $B \subset\subset A$, and for every compact subset K of B

$$F^+(u, A) \leq F^+(u, B) + F^+(u, A - K)$$

for every $u \in H^1(A)$. By Lemma 3.2 this implies that

$$F^+(u, A) = \sup\{F^+(u, B) : B \in \mathcal{A}, B \subset\subset A\}.$$

In order to prove Theorem 2.2 we have to show that for all $u \in H^1(\Omega)$

- a) $F^+(u, \Omega) \leq \int_{\Omega} f(Du) dx$
- b) $F^-(u, \Omega) \geq \int_{\Omega} f(Du) dx$

where f is the quadratic form defined in (2.5).

PROOF of PART a). By a standard density argument it is enough to prove a) only for a dense class in $H^1(\Omega)$, say the piecewise affine functions; moreover, by Lemma 3.5, Remark 3.6, and Lemma 3.2, we may reduce ourselves to consider only linear functions. Thus, let $u(x) = \langle z, x \rangle$ with $z \in \mathbb{R}^n$; our goal is to prove that

$$(3.10) \quad F^+(u, \Omega) \leq \text{meas}(\Omega) f(z).$$

Let $w_{\varepsilon,r,\lambda}$ be the solution of the problem

$$(3.11) \quad \min \left\{ \int_Y a_{1,r/\varepsilon,\lambda}(y) |z + Dw(y)|^2 dy : w \in W, \int_Y w(y) dy = 0 \right\},$$

and let

$$(3.12) \quad v_{\varepsilon,r,\lambda}(x) = u(x) + \varepsilon w_{\varepsilon,r,\lambda}(x/\varepsilon).$$

By Poincaré inequality, and by taking $w = 0$ in (3.11) we get

$$(3.13) \quad \begin{aligned} \int_Y |w_{\varepsilon,r,\lambda}(y)|^2 dy &\leq c \int_Y |Dw_{\varepsilon,r,\lambda}(y)|^2 dy \\ &\leq c \left[|z|^2 + \int_Y a_{\varepsilon,r,\lambda}(y) |z + Dw_{\varepsilon,r,\lambda}(y)|^2 dy \right] \\ &\leq c \left[|z|^2 + \int_Y a_{\varepsilon,r,\lambda}(y) |z|^2 dy \right] \leq c|z|^2, \end{aligned}$$

so that

$$\lim \int_{\Omega} \varepsilon^2 |w_{\varepsilon,r,\lambda}(x/\varepsilon)|^2 dx = \text{meas}(\Omega) \lim \varepsilon^2 \int_Y |w_{\varepsilon,r,\lambda}(y)|^2 dy = 0.$$

Hence $v_{\varepsilon,r,\lambda}$ tends to u in $L^2(\Omega)$. Now, we obtain

$$(3.14) \quad \begin{aligned} \lim \int_{\Omega} a_{\varepsilon,r,\lambda}(x) |Dv_{\varepsilon,r,\lambda}(x)|^2 dx \\ &= \text{meas}(\Omega) \lim \varepsilon^{-n} \int_{\varepsilon Y} a_{\varepsilon,r,\lambda}(x) |z + Dw_{\varepsilon,r,\lambda}(x/\varepsilon)|^2 dx \\ &= \text{meas}(\Omega) \lim \int_Y a_{1,r/\varepsilon,\lambda}(y) |z + Dw_{\varepsilon,r,\lambda}(y)|^2 dy. \end{aligned}$$

Since $r/\varepsilon \rightarrow 0$ and $\frac{\lambda r}{\varepsilon} \rightarrow k$, it is known (see Attouch [1], Carbone-Sbordone [10], Sanchez-Palencia [19]) that the functionals $F_{1,r/\varepsilon,\lambda} \Gamma(L^2(\Omega))$ converge to the functional

$$F_{1,0,\infty}(u, \Omega) = \int_{\Omega} |Du|^2 dx + k \int_{\Omega \cap S_1} |D_{\tau} u|^2 dH^{n-1},$$

so that

$$(3.15) \quad \begin{aligned} f(z) &= \min \{ F_{1,0,\infty}(\langle z, x \rangle + w, Y) : w \in W \} \\ &= \lim \int_Y a_{\varepsilon,r,\lambda}(y) |z + Dw_{\varepsilon,r,\lambda}(y)|^2 dy. \end{aligned}$$

Therefore, by (3.14) and (3.15)

$$F^+(u, \Omega) \leq \text{meas}(\Omega) f(z)$$

and (3.10) is proved. ■

PROOF OF PART b). As in part a), it is enough to prove b) for all piecewise affine functions; moreover, by Lemma 3.4 we may reduce ourselves to consider only linear functions. Thus, let $u(x) = \langle z, x \rangle$ with $z \in \mathbb{R}^n$ and let $(u_{\epsilon, r, \lambda})$ be a given family converging to u in $L^2(\Omega)$. Our goal is to prove that

$$(3.16) \quad \text{meas}(\Omega) f(z) \leq \liminf F_{\epsilon, r, \lambda}(u_{\epsilon, r, \lambda}, \Omega).$$

If the right-hand side is $+\infty$, (3.16) is obvious; otherwise, we may assume that (u_ϵ) stands for $u_{\epsilon, r, \lambda}$

$$(3.17) \quad \int_{\Omega} |Du_\epsilon|^2 dx + \lambda \int_{\Omega \cap S_{\epsilon, r}} |Du_\epsilon|^2 dx \leq c,$$

hence $u_\epsilon \rightarrow u$ weakly in $H^1(\Omega)$. Define $v_{\epsilon, r, \lambda}$ as in (3.12), and let $\varphi \in C_0^\infty(\Omega)$ be such that $0 \leq \varphi \leq 1$. Then we have

$$(3.18) \quad F_{\epsilon, r, \lambda}(u_\epsilon, \Omega) \geq \int_{\Omega} \varphi(x) a_{\epsilon, r, \lambda}(x) [|Dv_{\epsilon, r, \lambda}|^2 + 2 \langle Dv_{\epsilon, r, \lambda}, Du_\epsilon - Dv_{\epsilon, r, \lambda} \rangle] dx.$$

As in the proof of part a) we get

$$(3.19) \quad \lim \int_{\Omega} \varphi(x) a_{\epsilon, r, \lambda}(x) |Dv_{\epsilon, r, \lambda}|^2 dx = f(z) \int_{\Omega} \varphi(x) dx.$$

Moreover, since $\text{div}(a_{\epsilon, r, \lambda}(x) Dv_{\epsilon, r, \lambda}) = 0$, integrating by parts

$$(3.20) \quad \begin{aligned} & \lim \left| \int_{\Omega} \varphi(x) a_{\epsilon, r, \lambda}(x) \langle Dv_{\epsilon, r, \lambda}, Du_\epsilon - Dv_{\epsilon, r, \lambda} \rangle dx \right| \\ &= \lim \left| \int_{\Omega} (u_\epsilon - v_{\epsilon, r, \lambda}) a_{\epsilon, r, \lambda}(x) \langle Dv_{\epsilon, r, \lambda}, D\varphi \rangle dx \right| \\ &\leq c \lim \left[\int_{\Omega} a_{\epsilon, r, \lambda}(x) |u_\epsilon - v_{\epsilon, r, \lambda}|^2 dx \right]^{1/2} \left[\int_{\Omega} a_{\epsilon, r, \lambda}(x) |Dv_{\epsilon, r, \lambda}|^2 dx \right]^{1/2} \\ &\leq c \lim \left[\int_{\Omega} a_{\epsilon, r, \lambda}(x) |u_\epsilon - v_{\epsilon, r, \lambda}|^2 dx \right]^{1/2} \\ &\leq c \lim \left[\frac{\epsilon}{r} \int_{\Omega \cap S_{\epsilon, r}} |u_\epsilon - v_{\epsilon, r, \lambda}|^2 dx \right]^{1/2}. \end{aligned}$$

Recalling (3.13) and (3.17), by Lemma 3.1

$$\lim_{\frac{\varepsilon}{r}} \int_{\Omega \cap S_{\varepsilon,r}} |u_{\varepsilon} - v_{\varepsilon,r,\lambda}|^2 dx = 0,$$

so that, by (3.18), (3.19), (3.20)

$$\liminf F_{\varepsilon,r,\lambda}(u_{\varepsilon}, \Omega) \geq f(z) \int_{\Omega} \varphi(x) dx$$

and, since φ was arbitrary, (3.16) is proved. ■

THEOREM 3.7. *Let us consider*

$$(3.21) \quad F_{\varepsilon,r,\lambda}(u) = \int_{\Omega} a_{\varepsilon,r,\lambda}(x) \langle A(x)Du(x), Du(x) \rangle dx$$

$$\text{where} \quad a_{\varepsilon,r,\lambda}(x) = \begin{cases} \lambda & \text{if } x \in S_{\varepsilon,r} \\ 1 & \text{if } x \in \mathbb{R}^n \setminus S_{\varepsilon,r} \end{cases}$$

and A is a symmetric, positive definite matrix with continuous coefficients. The conclusions of Theorem 2.2 still hold with the following formula for f :

$$(3.22) \quad F(u) = \int_{\Omega} f(x, Du(x)) dx$$

$$(3.23) \quad f(x, z) = \min \left\{ \int_Y \langle A(x)Dv, Dv \rangle dy \right. \\ \left. + k \int_S \langle B(\sigma)Dv, Dv \rangle d\sigma; \quad v - \langle z, \cdot \rangle \in W \right\}$$

where the matrix B is related to A via the following formula:

$$(3.24) \quad \langle Bz, z \rangle = \langle Az, z \rangle - \frac{|\langle Az, \nu \rangle|^2}{\langle A\nu, \nu \rangle}$$

(ν is the normal vector to S).

PROOF of THEOREM 3.7. The proof is quite similar to the proof of Theorem 2.2, the only modification coming from formulae (3.23) and (3.24) which extend to the case of a matrix A (instead of the identity) the formula (3.15) (see Acerbi-Buttazzo-Percivale [21]).

4. Convergence of Dual Variables

The dual variables (momentum) $\sigma_{\epsilon,r,\lambda}$ whose expression is

$$(4.1) \quad \sigma_{\epsilon,r,\lambda} = a_{\epsilon,r,\lambda} \cdot Du_{\epsilon,r,\lambda}$$

play an important role too (in the elasticity model = stress tensor, in electrostatics = current field...) (see (2.1)... for the definition of $u_{\epsilon,r,\lambda}$). The convergence of $\sigma_{\epsilon,r,\lambda}$ cannot be obtained directly from the convergence of $a_{\epsilon,r,\lambda}$ and $u_{\epsilon,r,\lambda}$ since when $\frac{\lambda r}{\epsilon} \rightarrow k \in]0, +\infty[$,

$$\begin{aligned} a_{\epsilon,r,\lambda} &\rightarrow (1 + k|S|_{n-1})dx && \text{in } \sigma(M, C^0) \\ Du_{\epsilon,r,\lambda} &\rightarrow Du && \text{in } w - L^2(\Omega). \end{aligned}$$

The idea is to express $\sigma_{\epsilon,r,\lambda}$ as solution of a dual minimization problem. Following classical duality approach via perturbation functions (in the convex setting) let us introduce

$$(4.2) \quad F_{\epsilon,r,\lambda}(u, \tau) = \int_{\Omega} a_{\epsilon,r,\lambda}(x) |Du(x) + \tau(x)|^2 dx$$

where the perturbation variable τ is taken in $C^0(\Omega)$. The marginal function $h_{\epsilon,r,\lambda}$ is given by

$$(4.3) \quad h_{\epsilon,r,\lambda}(\tau) = \min_{v \in H_0^1(\Omega)} \left\{ F^{\epsilon}(v, \tau) + \int_{\Omega} g \cdot v \, dx \right\}$$

and $\sigma_{\epsilon,r,\lambda}$ is solution of

$$(4.4) \quad \min_{\sigma \in L^2(\Omega)} h_{\epsilon,r,\lambda}^*(\sigma).$$

For ϵ, r, λ fixed $\sigma_{\epsilon,r,\lambda}$ is clearly in $L^2(\Omega)$, but one cannot expect the sequence $\sigma_{\epsilon,r,\lambda}$ to be bounded better than in $L^1(\Omega)$! This is made clear by the following majorization (resp. minorization) of $h_{\epsilon,r,\lambda}$ (resp. $h_{\epsilon,r,\lambda}^*$):

$$(4.5) \quad h_{\epsilon,r,\lambda}(\tau) \leq \|\tau\|_{L^\infty}^2 \cdot \int_{\Omega} a_{\epsilon,r,\lambda} \leq C \cdot \|\tau\|_{L^\infty}^2 \quad (\text{take } v = 0 \text{ in (4.3)})$$

which in turn implies

$$(4.6) \quad h_{\epsilon,r,\lambda}^*(\sigma) \geq C \cdot \|\sigma\|_{L^1(\Omega)}^2.$$

Thus, in order to study the convergence of the sequence $(\sigma_{\epsilon,r,\lambda})$ by means of Γ -convergence method we have to prove the

(4.7) $\Gamma(\sigma(\mathcal{M}C^0))$ -convergence of the sequence $h_{\epsilon,r,\lambda}^*$
(see Proposition 2.1).

From the continuity properties of the Legendre-Fenchel transform with respect to Γ -convergence (see Attouch [1] and more precisely Aze [2] in this non reflexive setting), property (4.7) is equivalent to the

(4.8) $\Gamma(s - C^0)$ -convergence of the sequence $h_{\epsilon,r,\lambda}$.

The equi-local Lipschitz property of this sequence ($h_{\epsilon,r,\lambda}$) on C^0 (this is a direct consequence of (4.5)) makes the $\Gamma(s - C^0)$ convergence be equivalent to pointwise convergence; using again the variational properties of Γ -convergence and the definition of $h_{\epsilon,r,\lambda}$, the final problem is:

(4.9) for every $\tau \in C^0$ fixed, study the $\Gamma(s - L^2(\Omega))$ -convergence of $(F_{\epsilon,r,\lambda}(\cdot, \tau))$. This is solved by the following theorem:

THEOREM 4.1. i) For every $\tau \in C^0$ fixed there exists

$$\Gamma(L^2(\Omega)) \lim F_{\epsilon,r,\lambda}(\cdot, \tau) = F(\cdot, \tau)$$

$$\text{ii) we have } F(u, \tau) = \int_{\Omega} f(Du + \tau) dx$$

where f is given by the homogenization formula (2.5) of Theorem 2.2.

COROLLARY 4.2. The following convergence holds:

$$\sigma_{\epsilon,r,\lambda} = a_{\epsilon,r,\lambda} Du_{\epsilon,r,\lambda} \longrightarrow \sigma \text{ in } \sigma(\mathcal{M}, C^0)$$

where $\sigma = A(Du)$, u is the solution of the limit homogenized problem and $A = \partial f$ is the homogenized matrix associated to the quadratic form f (see (2.5)).

5. Some examples

In previous sections we computed the Γ -limit of the family of functionals

$$F_{\epsilon}(u) = \int_{\Omega} |Du|^2 dx + \epsilon \int_{\Omega \cap S_{\epsilon}} |D_{\tau}u|^2 dH^{n-1}.$$

A similar result can be obtained if the conductivity coefficient in Ω is assumed to be equal to $\delta > 0$, that is, the approximating energy functionals are

$$F_{\epsilon}(u) = \delta \int_{\Omega} |Du|^2 dx + \epsilon \int_{\Omega \cap S_{\epsilon}} |D_{\tau}u|^2 dH^{n-1}.$$

If δ is very small, the limit energy is close to $\int_{\Omega} f(Du)dx$, where the quadratic form f is given by

$$(5.1) \quad f(z) = \min \left\{ \int_S |D_{\tau}v|^2 dH^{n-1} : v - \langle z, \cdot \rangle \in W \right\}.$$

If the dimension n is equal to 2, formula (5.1) permits some explicit calculations. In fact, in this case S is a curve $\gamma(s)$ (assume it is parametrized by the curvilinear abscissa s), so that, indicating by L the length of γ , formula (5.1) becomes

$$f(z) = \min \left\{ \int_0^L | \langle z, \gamma'(s) \rangle + w'(s) |^2 ds \right\}$$

where the minimum is taken over all functions w satisfying the periodicity conditions. An analogous formula holds if S is the union of finitely many curves $\gamma_i(s)$ ($i = 1, \dots, N$):

$$(5.2) \quad f(z) = \min \left\{ \sum_{i=1}^N \int_0^{L_i} | \langle z, \gamma_i'(s) \rangle + w_i'(s) |^2 ds \right\}.$$

The advantage of formula (5.2) is that it is very easy to compute; in fact, the necessary conditions for minimum give

$$w_i'(s) = - \langle z, \gamma_i'(s) \rangle + c_i$$

where c_i are constants which can be obtained from the periodicity conditions. Then (5.2) becomes

$$f(z) = \sum_{i=1}^N L_i c_i^2.$$

We show now three examples of two-dimensional net structures for which we made this calculation.

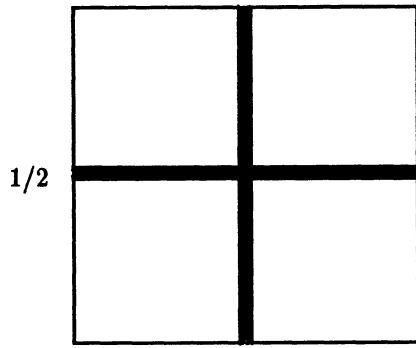
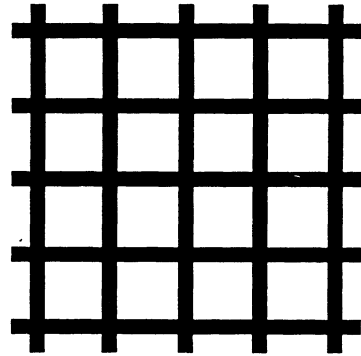

Fig. 2 Unitary cell



Network structure

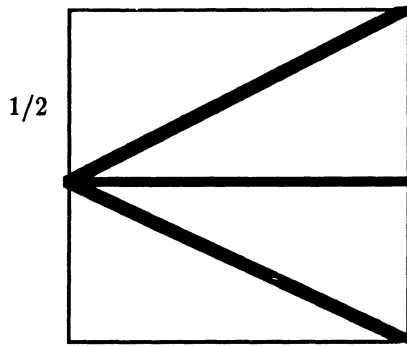
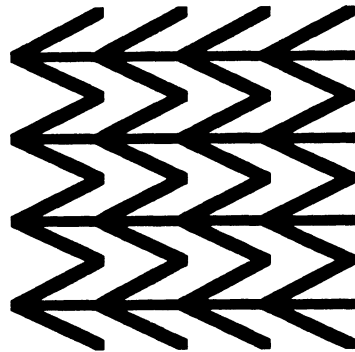
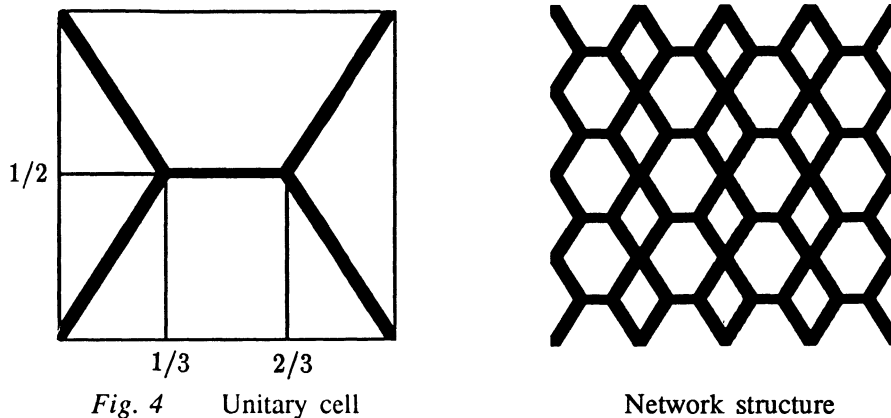

Fig. 3 Unitary cell



Network structure



After some elementary calculations we get:

in example of figure 2

$$f(z) = z_1^2 + z_2^2$$

in example of figure 3

$$f(z) = z_1^2 + \frac{\sqrt{5}}{5} z_2^2$$

in example of figure 4

$$f(z) = \frac{2}{3}(\sqrt{13} - 2)z_1^2 + \frac{6\sqrt{13}}{13} z_2^2.$$

REFERENCES

- [1] H. ATTOUCH, *Variational Convergence for Functions and Operators*. Pitman, Appl. Math. Ser., Boston (1984).
- [2] D. AZE, *Homogénéisation primale et duale par epi-convergence. Applications à l'élasticité*. Publications A VAMAC 84-06, Université de Perpignan, Perpignan (1984).
- [3] N.S. BAHVALOV - G.P. PANASENKO, *Averaged processes in periodic media*. Moscow, Nauka 1984 (in russian).
- [4] A. BENSOUSSAN - J.L. LIONS - G. PAPANICOLAOU, *Asymptotic Analysis for Periodic Structures*. North-Holland, Amsterdam (1978).
- [5] G. BUTTAZZO, *Su una definizione generale dei Γ -limiti*. Boll. Un. Mat. Ital., **14-B** (1977), 722-744.
- [6] G. BUTTAZZO - G. DAL MASO, *Γ -limits of integral functionals*. J. Analyse Math., **37** (1980), 145-185.
- [7] G. BUTTAZZO - G. DAL MASO, *Singular perturbation problems in the calculus of variations*. Ann. Scuola Norm. Sup. Pisa Cl. Sci., **11** (1984), 395-430.

