

ANNALES DE L'I. H. P., SECTION A

K. FREDENHAGEN

M. R. GABERDIEL

Scattering theory for plektons in 2 + 1 dimensions

Annales de l'I. H. P., section A, tome 64, n° 4 (1996), p. 523-541

http://www.numdam.org/item?id=AIHPA_1996__64_4_523_0

© Gauthier-Villars, 1996, tous droits réservés.

L'accès aux archives de la revue « Annales de l'I. H. P., section A » implique l'accord avec les conditions générales d'utilisation (<http://www.numdam.org/conditions>). Toute utilisation commerciale ou impression systématique est constitutive d'une infraction pénale. Toute copie ou impression de ce fichier doit contenir la présente mention de copyright.

NUMDAM

Article numérisé dans le cadre du programme
Numérisation de documents anciens mathématiques

<http://www.numdam.org/>

Scattering theory for plektons in $2 + 1$ dimensions

by

K. FREDENHAGEN (*)

II. Institut für Theoretische Physik
Universität Hamburg, D 22761 Hamburg, Germany

and

M. R. GABERDIEL (†)

Department of Applied Mathematics and Theoretical Physics,
University of Cambridge, Silver Street, Cambridge, CB3 9EW, U.K.

ABSTRACT. – Scattering states for particles with non-abelian braid group statistic, so called plektons, are constructed. The space of such states is shown to have the structure of a vector bundle associated to the universal covering space of the space of non-coinciding velocities in 3 dimensional Minkowski space.

RÉSUMÉ. – Nous construisons les états de collision de particules, les plektons, obéissant à une statistique donnée par un groupe de tresse non abélien. Nous montrons que l'espace de ces états admet une structure de fibré vectoriel associé au recouvrement universel de l'espace des vitesses non coïncidentes dans l'espace de Minkowski tridimensionnel.

(*) Email: i02fre@dsyibm.desy.de

(†) Email: M.R.Gaberdiel@damtp.cam.ac.uk

1. INTRODUCTION

Particle-like excitations which are confined to 2 spatial dimensions are not necessarily bosons or fermions. In general their statistics can only be described by some unitary representation of Artin's braid group [1]. These particles are usually referred to as "anyons" or "plektons" depending on whether the braid group representation is abelian or not.

The possible existence of plektons can be derived from two apparently disjoint principles. One is based on a quantum mechanical description of particle configurations in terms of sets of points in space. The principle of indistinguishability of identical particles then leads in 2 space dimensions to the occurrence of braid group representations characterizing the behavior of the wave functions under a permutation of the arguments [20]. The other derivation is based on the principles of quantum field theory in a $2 + 1$ dimensional spacetime. Particle-like excitations in massive models in general correspond to nonlocal fields which depend on a spacelike direction [2]. An analysis of the statistics of such particles by the methods of the DHR theory of superselection sectors [3] then leads in $2 + 1$ dimensions to the possible existence of nontrivial braid group representations [13, 14].

Models for anyons were first invented by Wilczek in [32], and non-abelian gauge theories with a Chern-Simons term in the action are believed to be candidates for models with non-abelian braid group statistics. (For another mechanism leading to plektons *see* also [5].) Whether plektons really occur in physical systems is unknown at the moment. Anyons are considered to be the excitations which are responsible for the Fractional Quantum Hall Effect [19].

It would be desirable to determine model independent (characteristic) properties of plektonic excitations. At present, little has been achieved in this way as there does not exist a description of free plektons which could be used as a basis for an analysis of systems of weakly coupled plektons. We therefore propose to explore the structure of plektonic multiparticle excitations as determined by the first principles of quantum field theory.

In the case of permutation group statistics the multiparticle space (as a representation space of the Poincaré group) is obtained by the choice of a Poincaré invariant metric (determined by the statistics) on the tensor product of Poincaré group representations on single particle spaces [3]. This is no longer true in the plektonic case because the sum rules for spins involve the statistics [7]. A multiplekton space with a representation of the Poincaré group was recently constructed by Mund and Schrader [23]: it

is determined by the Poincaré group representation in the single particle spaces and a representation of the braid group B_n .

It will turn out that the space of multiparticle scattering states of a massive, Poincaré covariant 2 + 1 dimensional theory, for which the fields exhibit in general braid group statistics [9, 14] has this proposed structure. To establish this result we construct scattering states, using the Haag-Ruelle construction. We then analyze the space of such states in detail and unveil its structure.

Due to the rather complicated localization properties of the fields certain difficulties arise. Firstly, to describe the product of particle representations by compositions of endomorphisms of an algebra of observables, we have to enlarge the algebra of local observables on Minkowski space $\mathcal{A}_0(\mathcal{M})$. To this end we use the formalism of [13, II] (*see also* [8], [16]) to extend $\mathcal{A}_0(\mathcal{M})$ to an algebra $\mathcal{A}_0(\overline{\mathcal{M}})$ which may be considered as the algebra of local observables on the union of Minkowski space with the hyperboloid at spacelike infinity. With respect to this algebra we then define the associated field bundle [3], an intrinsic structure equivalent to the exchange algebra of vertex operators [25] which is known from conformal field theory. We develop a new geometrical description for the (statistics) intertwiners in which the (geometrical) role of the braid group becomes apparent. Using this formulation we can then give a compact formula for the commutation relation of generalized fields.

Then we construct Haag-Ruelle approximants to scattering states. If we followed the same procedure as in [2] (*see e.g.* [15]), the resulting vectors which describe the scattering states would depend on (i) the Lorentz system, in which the Haag Ruelle approximants were defined, (ii) the “auxiliary direction” which was needed in [2] for the definition of field operators, and finally (iii) on the localization directions of the nonlocal fields which create the one particle states. It seems to be very difficult to disentangle this complicated dependence which is necessarily nontrivial in the case of proper braid group statistics. (In 3 + 1 dimensions the scattering vectors depend only on the corresponding one particle vectors, but the proof in [2] makes explicit use of the dimensionality of spacetime). In our approach the auxiliary direction does not appear, but now the localization direction is located on a covering space of the hyperboloid at spacelike infinity. In order to avoid a dependence on the Lorentz system we reformulate the Haag-Ruelle theory in a manifestly Lorentz invariant way by propagating each particle in its own rest frame. There remains the dependence on the directions but this dependence is physically meaningful and has to be investigated thoroughly.

Having constructed the scattering states we then turn to the calculation of their scalar products. These can be most easily computed using the concept of “right inverses”, recently introduced by Roberts [27]. This allows us to extend the calculation for the case of permutation statistics directly to the present situation.

Finally, we analyze the dependence on the localization directions. We show that the scattering vectors are locally independent of the spacelike directions which characterize the localization regions, and we find an explicit transformation formula (in terms of the statistic intertwiner relating scattering vectors corresponding to different sets of spacelike directions. This result enables us to unveil the global structure of the space of scattering vectors; the set of directions can be regarded as parametrizing local trivializations of the universal covering space \overline{C}_n of the configuration space C_n of n non-coincident velocities in 3-dimensional Minkowski space. And the space of scattering vectors has the structure of the Hilbert space of square integrable sections of a vector bundle which is associated to this covering space [29].

This structure (for the case of single particle spaces with an irreducible representation of the Poincaré group) was anticipated by Schrader [30] (*see also* [31]). The space of all scattering vectors is precisely the direct sum of the n -particle spaces of Mund and Schrader [23] where the braid group representations are induced by a Markov trace on the braid group B_∞ .

Some work in this direction has already been done by Fröhlich and Marchetti [15], who concentrated on the abelian case, and by Schroer [28], who pointed out problems and made some prospective remarks. The present work is largely a less technical summary of the results of [12].

2. THE UNIVERSAL ALGEBRA AND THE FIELD BUNDLE

The framework in which we shall work is that of algebraic quantum field theory. In particular, we are interested in the Buchholz-Fredenhagen situation of $2 + 1$ dimensional quantum field theory where the fields, generating the different sectors from the vacuum, are localized in space-like cones. These fields have been shown to exhibit braid group statistics [9, 14].

Let us briefly recall the axioms involved and introduce the notation. The local observables are described by von Neumann algebras $\mathcal{A}(\mathcal{O})$, indexed by the open double cones \mathcal{O} of Minkowski space \mathcal{M} , which satisfy *locality* and *isotony*. Locality means that algebra elements localized in spacelike separated double cones commute, and isotony requires that an algebra corresponding to \mathcal{O} is contained in an algebra corresponding to a

double cone containing \mathcal{O} . Given isotony, we can define the full algebra of observables, $\mathcal{A}_0(\mathcal{M})$, to be the norm closure of the union $\cup \mathcal{A}(\mathcal{O})$ of all local algebras. Moreover, for an arbitrary region $\mathcal{R} \subset \mathcal{M}$, we define $\mathcal{A}_0(\mathcal{R})$ to be the C^* -subalgebra of $\mathcal{A}_0(\mathcal{M})$ generated by all algebras $\mathcal{A}(\mathcal{O})$ with double-cones $\mathcal{O} \subset \mathcal{R}$, and $\mathcal{A}(\mathcal{R})$ to be its weak closure.

For simplicity we want to assume that the theory is Poincaré invariant. This means that there exists a representation α of the identity component P_+^\uparrow of the Poincaré group by automorphisms of $\mathcal{A}_0(\mathcal{M})$ such that $\alpha_{(x, \Lambda)}(\mathcal{A}(\mathcal{O})) = \mathcal{A}((x, \Lambda)(\mathcal{O}))$. There is an action of the algebra of observables $\mathcal{A}_0(\mathcal{M})$ (by bounded operators) on a Hilbert space \mathcal{H}_0 , the vacuum representation, and this space carries a strongly continuous unitary representation U_0 of P_+^\uparrow . The generators of the translations P_ν satisfy the spectrum condition

$$\text{sp } P \subset \{0\} \cup \{p \in \mathcal{M} | p^2 > \mu^2, p_0 > 0\} \quad (1)$$

for some $\mu > 0$. Finally, there is a unique cyclic unit vector $\Omega \in \mathcal{H}_0$, invariant under Poincaré transformations, which represents the vacuum.

We are interested in a purely massive, Poincaré covariant theory, in which all sectors describe massive particles. That means, that for the physically allowed representations $\pi : \mathcal{A}_0(\mathcal{M}) \rightarrow \mathcal{H}_\pi$, \mathcal{H}_π carries a strongly continuous representation U_π of the covering group $\widetilde{P_+^\uparrow}$ of P_+^\uparrow such that the generators of the translations satisfy the spectrum condition

$$H_m \subset \text{sp } P \subset H_m \cup \{p \in \mathcal{M} | p^2 > M^2, p_0 > 0\} \quad (2)$$

with $0 < m < M$. Here H_m is the mass shell $H_m = \{p \in \mathcal{M} | p^2 = m^2, p_0 > 0\}$ and m is interpreted as the mass of the particle described by π , π is called "massive single particle representation".

It was shown in [2] that for irreducible massive single particle representations π , there is a unique vacuum representation π_0 , *i.e.* a representation satisfying (2.2) (with $\mu \geq M - m$), such that π and π_0 are unitarily equivalent when restricted to the algebra of the causal complement of any spacelike cone S

$$\pi|_{\mathcal{A}_0(S')} \cong \pi_0|_{\mathcal{A}_0(S')}. \quad (3)$$

Here a spacelike cone S is the convex set

$$S := a + \bigcup_{\lambda > 0} \lambda \mathcal{O}, \quad (4)$$

where $a \in \mathcal{M}$ is the apex and \mathcal{O} is a double-cone of spacelike directions

$$\mathcal{O} = \{\tau = \mathcal{M} | r^2 = -1 \text{ and } r_+ - r, r - r_- \in V_+\} \quad (5)$$

with $r_+^2 = r_-^2 = -1$, $r_+ - r_- \in V_+$, V_+ denoting the interior of the forward light cone. We denote the set of spacelike cones by \mathcal{S} .

In view of this result we shall from now on fix the vacuum representation π_0 and identify it with the defining (identical) representation of $\mathcal{A}_0(\mathcal{M})$ on \mathcal{H}_0 . We consider only those massive single particle representations π which satisfy the ‘‘Buchholz-Fredenhagen criterion’’ (3) with respect to π_0 . Furthermore, we shall assume that the fixed vacuum representation fulfills Haag duality for spacelike cones, *i.e.*

$$\mathcal{A}(S') = \mathcal{A}(S)' \quad \text{for all } S \in \mathcal{S}. \quad (6)$$

To define multi-particle representations it is necessary to somehow multiply these single particle representations. To do this one describes the representations in terms of endomorphisms of some algebra of observables. These endomorphisms can then be composed to describe the corresponding product representations. In the present situation, representations can be described by endomorphisms of the *universal algebra* $\mathcal{A}_0(\overline{\mathcal{M}})$, which can be uniquely characterized by the following universality conditions (this construction was proposed in [8] and further developed in [16] and [13, II]):

- there are unital embeddings $i^I : \mathcal{A}(I) \rightarrow \mathcal{A}_0(\overline{\mathcal{M}})$ such that for all $I, J \in \mathcal{K} := \{S, S' | S \in \mathcal{S}\}$

$$i^J|_{\mathcal{A}(I)} = i^I \quad \text{if } I \subset J \quad (7)$$

and $\mathcal{A}_0(\overline{\mathcal{M}})$ is generated by the algebras $i^I(\mathcal{A}(I))$.

- for every family of normal representations $(\pi^I)_{I \in \mathcal{K}}$, $\pi^I : \mathcal{A}(I) \rightarrow B(\mathcal{H}_\pi)$ which satisfies the compatibility condition

$$\pi^J|_{\mathcal{A}(I)} = \pi^I \quad \text{if } I \subset J, \quad (8)$$

there is a unique representation π of $\mathcal{A}_0(\overline{\mathcal{M}})$ in \mathcal{H}_π such that

$$\pi \circ i^I = \pi^I. \quad (9)$$

The endomorphisms ρ corresponding to the representation π are characterized by the condition that the unique extensions of π and π_0 to $\mathcal{A}_0(\overline{\mathcal{M}})$ (which shall be denoted by the same symbols) satisfy ⁽¹⁾

$$\pi = \pi_0 \circ \rho. \quad (10)$$

It should be borne in mind, however, that the vacuum representation π_0 is in general no longer faithful on $\mathcal{A}_0(\overline{\mathcal{M}})$ (*see* [13, II] for details).

⁽¹⁾ From now on we shall consider $\mathcal{A}(I)$, $I \in \mathcal{K}$ as abstract subalgebras of $\mathcal{A}_0(\overline{\mathcal{M}})$ and only $\pi(A)$ (resp. $\pi_0(A)$) as operators on the vacuum Hilbert space \mathcal{H}_0 .

The endomorphisms ϱ one obtains are localized in some $I \in \mathcal{K}$ in the following sense [10].

DEFINITION 1. – An endomorphism ϱ of $\mathcal{A}_0(\overline{\mathcal{M}})$ is called localizable within $I \in \mathcal{K}$ if for all $I_0 \subset I$, $I_0 \in \mathcal{K}$ there exists a unitary $U \in \mathcal{A}(I)$ such that

$$\varrho(A) = \text{Ad } U(A), \quad A \in \mathcal{A}(I_0), \quad (11)$$

$$\text{Ad } U^* \circ \varrho(\mathcal{A}(I_1)) \subset \mathcal{A}(I_1), \quad I_1 \supset I_0, I_1 \in \mathcal{K}. \quad (12)$$

An endomorphism ϱ is called transportable if for every $I \in \mathcal{K}$ there exists an endomorphism ϱ' of $\mathcal{A}_0(\overline{\mathcal{M}})$ which is localizable within I and is inner equivalent to ϱ , i.e. there exists a unitary $U \in \mathcal{A}_0(\overline{\mathcal{M}})$ such that $\varrho' = \text{Ad } U \circ \varrho$.

Note that endomorphisms which are localizable within I are not necessarily localizable within $J \supset I$. However transportable endomorphisms which are localizable within some region are automatically localized in every larger region. We denote by Δ the set of transportable endomorphisms and by $\Delta(I)$ the subset of transportable endomorphisms which are localizable within I .

In the $s + 1$ -dimensional situation, $s \geq 3$, it is possible to embed $\mathcal{A}_0(\mathcal{M})$ into a net of field algebras \mathcal{F} which transform covariantly under some compact group of internal symmetries and satisfy graded locality [4]. These fields may generate single particle states from the vacuum, and one can use them for the construction of multiparticle scattering states by the standard recipe of the Haag-Ruelle theory [17, 18]. In the present 2 + 1 dimensional situation, however, a general construction of field algebras is difficult, even though some progress has been made [22, 26]. We therefore return to the original construction of scattering states used in [3] and [2]. This method is based on the fact that the partial intertwiners which exist between representations satisfying a localizability condition of the type (3) behave in many respects in the same way as field operators. They can be conveniently described by the so-called field bundle formalism which was introduced in [3, II].

Let S_0 be a spacelike cone. We describe vectors Ψ in some representation $\pi_0 \circ \varrho$ by a pair $\Psi = \{\varrho; \Psi\}$ and consider $\Delta(S_0) \times \mathcal{H}_0 = \mathcal{H}$ as a hermitian vector bundle over $\Delta(S_0)$, where on every fiber $\mathcal{H}_\varrho = \{\varrho\} \times \mathcal{H}_0$ the scalar product is that of \mathcal{H}_0 . Generalized field operators are pairs $\mathbf{B} = \{\varrho; B\} \in \Delta(S_0) \times \mathcal{A}_0(\overline{\mathcal{M}})$ which act on \mathcal{H} by $\{\hat{\varrho}; B\} \{\varrho; \Psi\} = \{\varrho \hat{\varrho}; \pi_0 \circ \varrho(B) \Psi\}$ and possess the norm $\|\{\hat{\varrho}; B\}\| := \|B\|$. Field operators have an associative multiplicative structure given by

$$\{\varrho_1; B_1\} \{\varrho_2; B_2\} := \{\varrho_2 \varrho_1; \varrho_2(B_1) B_2\}. \quad (13)$$

The formalism contains a large redundancy which can be described by the action of *intertwiners* $T \in \mathcal{A}_0(\overline{\mathcal{M}})$ satisfying $\varrho_1(A)T = T\varrho(A)$, $A \in \mathcal{A}_0(\overline{\mathcal{M}})$. Here T is an intertwiner from ϱ to ϱ_1 and it induces the actions

$$(\varrho_1 |T| \varrho) \{ \varrho; \Psi \} = \{ \rho_1; \pi_0(T) \Psi \}, \quad (\varrho_1 |T| \varrho) \circ \{ \varrho; B \} = \{ \rho_1; TB \}. \quad (14)$$

The Poincaré group acts on vectors $\Psi = \{ \varrho; \Psi \}$ via U_ϱ , where U_ϱ is the representation of $\widetilde{\mathcal{P}}_+^\uparrow$ corresponding to $\pi = \pi_0 \circ \varrho$. The representation of the identity component of the Poincaré group on $\mathcal{A}_0(\mathcal{M})$ lifts to a representation on the generalized field operators. However, due to the fact that the vacuum representation π_0 is not faithful on $\mathcal{A}_0(\overline{\mathcal{M}})$, this representation can only be defined locally (see [13, II] and [12] for details).

3. LOCALIZATION AND COMMUTATION RELATIONS

Usually, the localization property of a generalized field operator $\mathbf{B} = \{ \varrho; B \}$ is already characterized by the condition that \mathbf{B} intertwines the identity with ϱ on the algebra of the spacelike complement of the localization region. However, due to the existence of global self-intertwiners in $\mathcal{A}_0(\overline{\mathcal{M}})$, this condition is too weak to allow for a derivation of commutation relations in the present situation. We therefore characterize the localization instead by a path in \mathcal{K} , *i.e.* a finite sequence $I_i \in \mathcal{K}$, $i = 0, \dots, n$ with $I_0 = S_0$ and such that either $I_i \subset I_{i-1}$ or $I_i \supset I_{i-1}$, $i = 1, \dots, n$. For each i there is some unitary $U_i \in \mathcal{A}(I_i \cup I_{i-1})$ such that $\text{Ad } U_i \dots U_1 \circ \varrho \in \Delta(I_i)$. Then $\{ \varrho, B \}$ is called localized in (I_0, \dots, I_n) if

$$U_n \dots U_1 B \in \mathcal{A}(I_n). \quad (15)$$

The concept of localization described above is an extension of the corresponding notion in [3] following ideas of [13, II]. Clearly, the localization depends only on the homotopy class \bar{I} of a path (I_0, \dots, I_n) where homotopy is defined in the obvious way. The set of these classes shall be denoted by $\bar{\mathcal{K}}$ and the set of field operators localized in \bar{I} by $\mathcal{F}(\bar{I})$.

Let us now consider paths with the same endpoint. They differ (up to homotopy) by a closed path $\gamma = (I_0, \dots, I_k)$ with $I_k = I_0$. We choose associated intertwiners U_1, \dots, U_k with $\pi_0(U_k \dots U_1) = 1$. Then $\gamma \mapsto U(\gamma) = U_k \dots U_1$ is a representation of the homotopy group by unitary elements of $\mathcal{A}_0(\overline{\mathcal{M}})$.

Field operators which are mutually spacelike localized have well-defined commutation relations. Here mutually spacelike means that the endpoint $e(\bar{I}) = I_n$ of the localization path $(I_0 = S_0, \dots, I_n) = \bar{I}$ of one operator is spacelike separated from the endpoint $e(\bar{J}) = J_k$ of the localization path $(J_0 = S_0, \dots, J_k) = \bar{J}$ of the other. For a product of mutually spacelike separated field operators $\mathbf{B}_i = \{\varrho_i, B_i\}$; localized in \bar{I}_i , $i = 1, \dots, n$ the commutation relations are given as

$$\mathbf{B}_{\sigma(n)} \dots \mathbf{B}_{\sigma(1)} = \varepsilon \circ \mathbf{B}_n \dots \mathbf{B}_1, \quad (16)$$

where ε is an intertwiner from $\varrho_1 \dots \varrho_n$ to $\varrho_{\sigma(1)} \dots \varrho_{\sigma(n)}$ and σ is a permutation. ε depends on the endomorphisms $\varrho_i \in \Delta(S_0)$, on the localizations \bar{I}_i and on σ . It is described in terms of a unitary representation of the groupoid of colored braids on the cylinder [13, II]. An alternative description which exhibits the topological role of the braid group in the theory can be obtained by the following geometrical construction.

Mutually spacelike paths \bar{I}_i are continuously deformed to paths γ_i on the set of spatial directions in some Lorentz frame, *i.e.* to paths on the circle S^1 with a fixed initial point z_0 corresponding to I_0 and disjoint endpoints z_i corresponding to the endpoints $e(\bar{I}_i)$ of \bar{I}_i . On the cylinder $S^1 \times \mathbb{R}$ we choose points (z_0, i) , $i = 1, \dots, n$ and paths Γ_i from (z_0, i) to $(z_0, \sigma(i))$,

$$\Gamma_i = (\gamma_i^{-1}, \sigma(i)) \circ (z_i, i \rightarrow \sigma(i)) \circ (\gamma_i, i). \quad (17)$$

The braid is now the usual equivalence class of the family of strands Γ_i , $i = 1, \dots, n$ (*see* for example figure 1, where the 3rd dimension is introduced for visualizing the parameter of the paths $(\lambda_i, i \rightarrow \sigma(i))$).

By the standard techniques of algebraic field theory (*see* [3, 13] for more details) it follows that ε is invariant under small deformations of $\bar{I}_1, \dots, \bar{I}_n$ —so equivalent families Γ_i , $i = 1, \dots, n$ give the same intertwiner ε — and that the braid relations are respected.

4. CLUSTER PROPERTY

Let us briefly recall the notion of a *left inverse* of an endomorphism $\varrho \in \Delta(S_0)$ (*see* [13], [6], [21] for more details): A left inverse ϕ of a ϱ is a positive mapping of $\mathcal{A}_0(\overline{\mathcal{M}})$ mapping $\mathcal{A}(S_0)$ into itself such that $\phi \circ \varrho = \text{id}$ and such that $\varrho \circ \phi$ is a conditional expectation from $\mathcal{A}_0(\overline{\mathcal{M}})$ to $\varrho(\mathcal{A}_0(\overline{\mathcal{M}}))$. If ϱ is irreducible and has finite statistics the left inverse of ϱ is unique. If $\varrho_1, \dots, \varrho_n \in \Delta(S_0)$ are irreducible with finite statistics, the

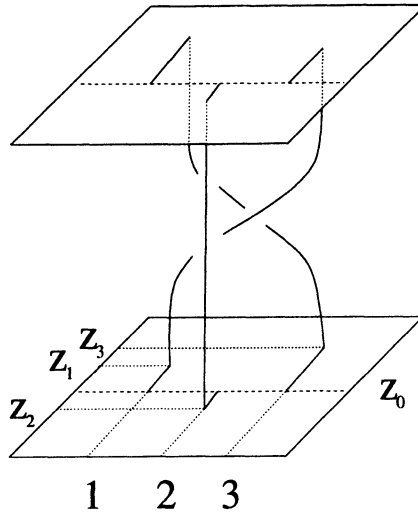

Fig. 1. – The braid corresponding to the permutation $\sigma = \tau_1 \tau_2 \tau_1$ in the special case where all three paths γ_i have trivial winding number and thus can be represented as paths in the plane.

product $\varrho = \varrho_1 \dots \varrho_n$ is not irreducible in general, and there is no unique left inverse. But there exists a so called standard left inverse which is given by

$$\phi = \phi_n \dots \phi_1, \tag{18}$$

where ϱ_i is the unique left inverse of ϱ_i , $i = 1, \dots, n$.

We also need the notion of a *right inverse* of an endomorphisms which has been recently introduced by Roberts [27]. The right inverse of ϱ is only defined on the class of intertwiners of the form $(\varrho'' \varrho | T | \varrho' \varrho)$. For such an intertwiner, the right inverse, $\chi_\varrho(T)$, is an intertwiner from ϱ' to ϱ'' . If ϱ has a conjugate representation, a right inverse of ϱ can be defined as

$$\chi_\varrho(T) = \varrho'' (\bar{R})^* T \varrho' (\bar{R}), \tag{19}$$

when \bar{R} is an isometric intertwiner from the vacuum representation to $\varrho\bar{\varrho}$. Roberts has shown that there is a unique right inverse, the *standard right inverse*, which agrees with the standard left inverse on local self-intertwiners. The standard right inverse is unique for irreducible ϱ with finite statistics. Furthermore, the product of standard right inverses is the standard right inverse of the composite endomorphism.

We are now in the position to state a version of the cluster theorem [3] which is adapted to the present situation and which will be needed later on for the calculation of scalar products of scattering states.

LEMMA 2 (Cluster Theorem). – Let $\mathbf{B}_i = \{\varrho_i, B_i\} \in \mathcal{F}(\tilde{I}_i)$, $i = 2, 4$ with $\tilde{I}_2 = \tilde{I}_4$ and let $\mathbf{B}_j = \{\varrho_j, B_j\}$, $j = 1, 3$ be products of field operators.

For fixed e , $e^2 = 1$ let τ be the supremum of $|t|$ for all t for which all the field operators in \mathbf{B}_1 and \mathbf{B}_3 are spacelike localized with respect to $I_2 + te$. Furthermore, let T be an intertwiner from $\varrho_1\varrho_2$ to $\varrho_3\varrho_4$. We are interested in the leading behavior of $(\mathbf{B}_4\mathbf{B}_3\Omega, T\mathbf{B}_2\mathbf{B}_1\Omega)$ for larger τ . Let us assume that ϱ_4 is irreducible with finite statistics with right inverse χ_4 and denote by $\{W_j\}$ a (possibly empty) orthonormal basis of the Hilbert space of local intertwiners from ϱ_4 to ϱ_2 . Then

$$\begin{aligned} & |(\mathbf{B}_1\mathbf{B}_3\Omega, T\mathbf{B}_2\mathbf{B}_1\Omega) - \sum_j (\mathbf{B}_3\Omega, \chi_4(T\varrho_1(W_j))\mathbf{B}_1\Omega) \\ & \times (\mathbf{B}_4\Omega, W_j^*\mathbf{B}_2\Omega)| \leq e^{-\mu\tau} \prod_i \|\mathbf{B}_i\|. \end{aligned} \quad (20)$$

A proof can be found in [12]. The essential idea is a reformulation of the proof of the corresponding Lemma 7.3 in [3, II] in terms of right inverses. The proof which in its original form relied on permutation group statistics then directly extends to the case of nontrivial braid group statistics.

5. SCATTERING STATES

To construct scattering states we follow the general recipe of the Haag-Ruelle theory (for an introduction *see* [18]): we first construct almost local one particle creation operators \mathbf{B}_i (here almost localized in spacelike cones) and propagate them to other times using the Klein Gordon equation. In this way we obtain operators $\mathbf{B}_i(t)$ which are essentially localized at time t and create one particle state vectors $\Psi_i = \mathbf{B}_i(t)\Omega$ independent of t . We then show that the states

$$\mathbf{B}_n(t)\dots\mathbf{B}_1(t)\Omega \quad (21)$$

converge for $t \rightarrow \pm\infty$ and interpret the limit as the outgoing (incoming) scattering state vector corresponding to the single particle vectors Ψ_i , $i = 1, \dots, n$.

To be more precise, let $\mathbf{B} \in \mathcal{F}(\tilde{I})$ for some localization $\tilde{I} \in \tilde{\mathcal{K}}$, where the energy momentum spectrum $\text{sp}_{\mathbf{U}}\mathbf{B}\Omega$ contains an isolated mass shell H_m . Let furthermore $f \in \mathcal{S}(\mathcal{M})$ have a Fourier transform \tilde{f} with compact support in V_+ such that $\text{supp } \tilde{f} \cap \text{sp}_{\mathbf{U}}\mathbf{B}\Omega \subset H_m$. Then, for

$$f_t(x) = (2\pi)^{-\frac{3}{2}} \int d^3p e^{-ipx+i\left(\frac{p^2-m^2}{2}\right)t} \tilde{f}(p), \quad (22)$$

the operator

$$\mathbf{B}(t) := \int d^3x f_t(x) \alpha_x(\mathbf{B}), \tag{23}$$

creates a one particle state $\mathbf{B}(t)\Omega = \Psi$ of mass m which does not depend on t .

By the standard techniques of the stationary phase approximation (see e.g. [24]), we can show [12] that $\mathbf{B}(t)$ can be approximated by operators $\mathbf{B}_e(t) \in \mathcal{F}(\tilde{I} + tV_e(f))$,

$$\mathbf{B}_e(t) = \int_{tV_e(f)} d^3x f_t(x) \alpha_x(\mathbf{B}), \tag{24}$$

such that $\|\mathbf{B}(t) - \mathbf{B}_e(t)\| < c_N |t|^{-N}$ for suitable constants c_N . Moreover, the norms of the operators (23) are bounded by $\|\mathbf{B}(t)\| < c(1 + |t|^3)$. Here

$$V_e(f) = \left\{ v \in \mathcal{M}, \text{dist}\left(v, \frac{p}{m}\right) < \varepsilon \text{ for some } p \in \text{supp } \tilde{f} \right\} \tag{25}$$

is the *velocity support* of f .

To construct multiparticle scattering states, let $\tilde{I}_i \in \tilde{\mathcal{K}}$, $\mathbf{B}_i \in \mathcal{F}(\tilde{I}_i)$, $\tilde{f}_i \in C_0^\infty(V_+)$, $\varepsilon_i > 0$, $i = 1, \dots, n$ be a configuration such that the regions $\tilde{I}_i + tV_{\varepsilon_i}(f_i)$ are mutually spacelike for large t . Then the limit

$$\lim_{t \rightarrow \infty} \mathbf{B}_n(t) \dots \mathbf{B}_1(t) \Omega \tag{26}$$

exists and may be interpreted as a vector describing an outgoing configuration of n particles with state vectors $\Psi_i = \mathbf{B}_i(t)\Omega$. As long as the localizations \tilde{I}_i are kept fixed the scattering vectors depend only on these one particle vectors. Hence we may write

$$\lim_{t \rightarrow \infty} \mathbf{B}_n(t) \dots \mathbf{B}_1(t) \Omega = (\Psi_n, \tilde{I}_n) \times \dots \times (\Psi_1, \tilde{I}_1). \tag{27}$$

It is also easy to see how the Poincaré group acts

$$\mathbf{U}(L)(\Psi_n, \tilde{I}_n) \times \dots \times (\Psi_1, \tilde{I}_1) = (\mathbf{U}(L)\Psi_n, L\tilde{I}_n) \times \dots \times (\mathbf{U}(L)\Psi_1, L\tilde{I}_1), \tag{28}$$

and how the scattering vectors depend on the order of the one particle vectors

$$(\Psi_{\sigma(n)}, \tilde{I}_{\sigma(n)}) \times \dots \times (\Psi_{\sigma(1)}, \tilde{I}_{\sigma(1)}) = \varepsilon(b)(\Psi_n, \tilde{I}_n), \tag{29}$$

where b is the cylinder braid defined in section 3. Recall that ε acts via the vacuum representation. Since the intertwiner describing the transition from \tilde{I}_1 to other sheets is trivially represented in the vacuum, $\pi_0 \circ \varepsilon$ is actually a representation of the groupoid of colored braids on the plane.

To calculate the scalar products of scattering vectors we can use the cluster theorem to reduce the n -particle scalar products to products of one particle scalar products. The precise statement is the following.

THEOREM 3. – Let $V_i \subset H_1$ be compact and $\tilde{I}_i \in \tilde{\mathcal{K}}$, $i = 1, \dots, n$ such that for suitable neighborhoods V_i^ε of V_i in V_+ the regions $tV_i^\varepsilon + \tilde{I}_i$ are mutually spacelike for large t , and let f_i be test-functions with $\text{supp } \tilde{f}_i \subset V_i^\varepsilon$. Let $\mathbf{B}_i, \mathbf{C}_i \in \mathcal{F}(\tilde{I}_i)$ with associated single particle representations ϱ_i and σ_i , respectively, $i = 1, \dots, n$. Let $T \in \mathcal{A}(S_0)$ be an intertwiner from $\sigma_1 \dots \sigma_n$ to $\varrho_1 \dots \varrho_n$ and ϕ_i be the unique left inverse of ϱ_i , $i = 1, \dots, n$. Then, writing $\Psi_i = \mathbf{B}_i(t)\Omega$, $\Phi_i = \mathbf{C}_i(t)\Omega$, we find

(i) If ϱ_i is not equivalent to σ_i for some $i \in \{1, \dots, n\}$, then

$$((\Psi_n, \tilde{I}_n) \times \dots \times (\Psi_1, \tilde{I}_1), T(\Phi_n, \tilde{I}_n) \times \dots \times (\Phi_1, \tilde{I}_1)) = 0. \quad (30)$$

(ii) If $\varrho_i = \sigma_i$, $i = 1, \dots, n$, then

$$\begin{aligned} & ((\Psi_n, \tilde{I}_n) \times \dots \times (\Psi_1, \tilde{I}_1), T(\Phi_n, \tilde{I}_n) \times \dots \times (\Phi_1, \tilde{I}_1)) \\ &= \phi_n \dots \phi_1(T) \prod_i (\Psi_i, \Phi_i). \end{aligned} \quad (31)$$

The proof follows directly from the lemma and the observation that the standard right inverse $\chi_1 \dots \chi_n$ of $\varrho_1 \dots \varrho_n$ agrees with the standard left inverse $\phi_n \dots \phi_1$ on local intertwiners.

Thus the scattering vectors depend in a continuous way on the one particle vectors. Since $\mathcal{F}(\tilde{I})$ is dense in \mathcal{H} for all $\tilde{I} \in \tilde{\mathcal{K}}$ we find, by going to the closure, all scattering states corresponding to single particle states with prescribed momentum support.

6. THE STRUCTURE OF SCATTERING STATES

To unveil the structure of the space of scattering vectors it is important to understand the dependence of the scattering vectors on the localizations $\tilde{I}_i \in \tilde{\mathcal{K}}$. To this end, let us assume that there exists for some $j \in \{1, \dots, n\}$ a localization $\tilde{J}_j \in \tilde{\mathcal{K}}$, a field operator $\mathbf{C}_j \in \mathcal{F}(\tilde{J}_j)$ and a test function g_j with $\text{supp } \tilde{g}_j \subset m_j V_\varepsilon(f_j)$ such that

$$\Psi_j = \mathbf{C}_j(t)\Omega, \quad (32)$$

where $\mathbf{C}_j(t)$ is defined in analogy to (23) and $\tilde{J}_j + tV_\varepsilon(f_j)$ is spacelike to $\tilde{I}_i + tV_\varepsilon(f_i)$ for $i \neq j$ and large t . If $j = 1$ the scattering vector (27) does

not change when $\mathbf{B}_j(t)$ is replaced by $\mathbf{C}_j(t)$. If $j \neq 1$ we first commute $\mathbf{B}_j(t)$ to the right, then replace it by $\mathbf{C}_j(t)$ and commute it back to the j -th place. The whole procedure amounts to an application of an intertwiner $\varepsilon(b)$ to the scattering vector where b is a pure cylinder braid obtained by the prescription of section 3.

It is clear that the scattering vectors do not change when the localizations are translated or made smaller. Hence we may label the configurations $\tilde{\mathbf{I}}$ by points \tilde{r}_i in the covering space of the spacelike hyperboloid $\{x \in \mathcal{M}, x^2 = -1\}$. Moreover, the embeddings are locally constant in $\tilde{r}_2, \dots, \tilde{r}_n$ and are globally constant in \tilde{r}_1 .

Because of the condition that $\tilde{J}_j + t V_\varepsilon(f_j)$ is spacelike to $\tilde{I}_i + t V_\varepsilon(f_i)$ for $i \neq j$, the set of allowed configurations \tilde{r}_i depends on the velocities of the one particle states involved. Furthermore, for generic configurations of non-coinciding velocities, there exists a canonical choice for \tilde{r}_i . We can use this fact, to translate (essentially) the dependence on the configurations \tilde{r}_i into an (additional) dependence on the velocity configurations. It will then turn out that the scattering vectors depend actually on points in the covering space of the space of non-coinciding velocities, and that they possess a monodromy which we calculate explicitly. Assuming certain analyticity properties (which follow for example from the Poincaré covariance) this amounts to showing that the space of scattering vectors is a vector bundle associated to the universal covering space of the space of non-coinciding velocities in 3-dimensional Minkowski-space.

To be a bit more precise, let us introduce the following notation. Let $e_0 \in H_1$ be arbitrary. A configuration of disjoint particle velocities $q_i = \frac{p_i}{m_i} \neq q_j = \frac{p_j}{m_j}, i \neq j$, is called *regular* (with respect to e_0) if there are mutually spacelike cones S_i with apex e_0 such that $q_i \in S_i$ (in particular $q_i \neq e_0$). To a regular configuration $\mathbf{q} = (q_1, \dots, q_n)$ we associate a configuration of spacelike directions $\mathbf{r} = (r_1, \dots, r_n)$, with $r_i = q_i - e_0$.

We now pick a regular “reference” configuration \mathbf{q}^0 and choose n homotopy classes of paths of spacelike cones $\tilde{I}_i^0, i = 1, \dots, n$ whose endpoints $e(\tilde{I}_i^0)$ correspond to the canonical directions r_i^0 . We label these homotopy classes by $\tilde{\mathbf{r}}^0$. We also choose a unitary local self-intertwiner U^0 . For given one particle vectors Ψ_i whose velocity supports are centered around q_i^0 , we can then unambiguously define a n -particle scattering vector as

$$U^0(\Psi_n, \tilde{I}_n^0) \times \dots \times (\Psi_1, \tilde{I}_1^0). \tag{33}$$

Now, let γ_q be a path from q^0 to a regular configuration q which has the property that none of the n velocities passes through e_0 . We want to associate to γ_q a way of assigning a n -particle scattering vector to n one particle vectors Ψ_i whose velocity supports are centered around q_i . Given the one particle vectors, we want to require that this map is locally independent of the endpoint q of γ_q .

This can be done as follows. As before, we describe the spacelike directions r^0 by the n -points $(r_1^0, 1), \dots, (r_n^0, n)$ on the cylinder $S^1 \times \mathbb{R}_+$. As long as $q(t)$ is regular, the corresponding path $r(t)$ is canonically determined. At a critical point, where $q(t)$ ceases to be regular two directions r_k and r_m coincide ⁽²⁾. In a neighborhood of this critical point we define $r(t)$ by the following prescription. We move the direction r_l corresponding to the *smaller* velocity from (r_l, l) to $(r_l, 1/2)$, then change the tow directions past each other and finally move $(r'_l, 1/2)$ back to (r'_l, l) . Geometrically, this means that the points $r(t)$ on the cylinder, viewed from the $(S^1, 0)$ -end of the cylinder and looking in the long direction, perform the same motion as the velocities $q(t)$ when viewed from e_0 (compare fig. 2). We denote the so determined path $r(t)$ by $\gamma^r = (\gamma_1^r, \dots, \gamma_n^r)$.

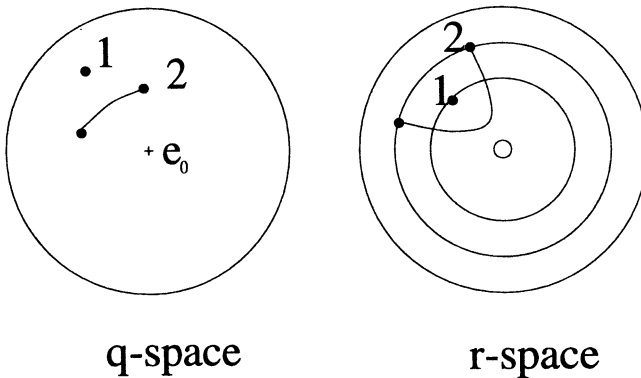

Fig. 2. – A path $q(t)$ and the corresponding path $r(t)$.

Each path γ_i^r lifts to a unique path $\tilde{\gamma}_i^r$ from \tilde{r}_i^0 to \tilde{r}_i . We denote the corresponding configuration by $\tilde{r} = (\tilde{r}_1, \dots, \tilde{r}_n)$. Each path γ_q therefore determines a pure braid on the cylinder, namely the homotopy class

$$b(\gamma_q) = (\tilde{r})^{-1} \circ \gamma^r \circ (\tilde{r}^0). \tag{34}$$

⁽²⁾ This is the generic case. The general case is covered by the geometrical description given below.

Note that b defines a homomorphism of the groupoid of colored braids on the cylinder (corresponding to paths $\gamma_{\mathbf{q}}$, where \mathbf{q} is a permutation of \mathbf{q}^0) to the pure braid group of the cylinder. This homomorphism is actually an automorphism of the pure braid group of the cylinder when restricted to closed paths $\gamma_{\mathbf{q}^0}$. (Both properties can be easily seen from the geometrical description.) Note also, that the image of a given path does not depend on the choice of e_0 locally.

Given n one particle vectors Ψ_i whose velocity supports are centered around q_i , we then unambiguously define the n particle scattering vector as

$$U^0 \varepsilon (b(\gamma_{\mathbf{q}}))^{-1} (\Psi_n, \tilde{I}_n) \times \dots \times (\Psi_1, \tilde{I}_1), \tag{35}$$

where \tilde{I}_i corresponds to \tilde{r}_i .

It remains to show that this definition is locally independent of \mathbf{q} . It is clear that this is the case if \mathbf{q} remains in the same component of the space of regular velocity configurations. Suppose therefore, that \mathbf{q}_1 and \mathbf{q}_2 lie in two different components, and that $\gamma_{\mathbf{q}_1}$ differs from $\gamma_{\mathbf{q}_2}$ by a path with only one critical point where two neighboring localization directions, r_k and r_n , coincide. We want to show that

$$\begin{aligned} U^0 \varepsilon (b(\gamma_{\mathbf{q}_1}))^{-1} (\Psi_n, \tilde{I}_n^1) \times \dots \times (\Psi_1, \tilde{I}_1^1) \\ = U^0 \varepsilon (b(\gamma_{\mathbf{q}_2}))^{-1} (\Psi_n, \tilde{I}_n^2) \times \dots \times (\Psi_1, \tilde{I}_1^2), \end{aligned} \tag{36}$$

where \tilde{I}^j are the localization paths corresponding to $\gamma_{\mathbf{q}_j}$ for $j = 1, 2$ and Ψ_i are one particle vectors with suitable velocity supports so that the two n -particle scattering vectors are well-defined.

On the left hand side we commute (using (29)) the field operator creating the particle with the *smaller* velocity (of the two particles k and m) to the right. We then change its localisation to the localization corresponding to \tilde{I}^2 and commute it back, using (29) again. (We have to change the localization region of the vector with the smaller velocity in order to guarantee that the two localization regions (corresponding to k and m) become mutually spacelike for large t for both \tilde{I}^1 and \tilde{I}^2 .) Doing this we pick up a pure braid, which is precisely the pure braid corresponding to the path from \mathbf{q}_1 to \mathbf{q}_2 via (34). As the two intertwiners in (36) differ by this braid, this establishes the identity.

We have thus shown how the dependence of the scattering vectors on the localization properties of the one particle creation operators can be translated into an dependence of the scattering vectors on the covering space of the space of n non-coinciding velocities. We can directly read off

the monodromy: if $\gamma_{\mathbf{q}^0}$ is a pure braid in the homotopy class of \mathbf{q}^0 , then the intertwiner, corresponding to $\gamma_{\mathbf{q}^0}$ is

$$U^0 \varepsilon (b(\gamma_{\mathbf{q}^0}))^{-1}, \quad (37)$$

where b is the automorphism of the pure braid group defined in (34). It can also be shown that this description is independent of e_0 [12].

If the space of n particle scattering vectors has locally the structure of a function space over the configuration space of non-coinciding velocities (this can be shown, for example, under the assumption of Lorentz covariance as assumed here), the space of n particle scattering vectors has the structure of the Hilbert space of square integrable sections of a vector bundle over this configuration space. In this case, the above analysis shows that this vector bundle is associated to the universal covering space via the above monodromy [29]. This is precisely the structure proposed by Schrader [30] and Mund and Schrader [23]. More details about the technicalities can be found in [12].

7. CONCLUSIONS

Within the framework of algebraic quantum field theory we have constructed scattering states for particles with non-abelian braid group statistics. The scattering states depend in a subtle way on the localization regions of the generalized field operators with which the corresponding one particle vectors can be constructed. We analyzed this dependence in detail. As the localization regions are intimately linked to the velocities of the corresponding one particle vectors, the dependence on the localization regions can be translated into a dependence on the velocity configurations. It turns out that the scattering vectors depend then on the covering space of the configuration space of non-coinciding velocities, where the vectors in different sheets are related by a “monodromy intertwiner” which we calculate explicitly. This demonstrates that the space of scattering vectors has the structure of a vector bundle, associated to the universal covering space of the space of non-coinciding velocities.

The analysis suggests how one might try to construct local fields with non-abelian braid group statistics. In particular, one should expect that the creation and annihilation operators depend on some spacelike direction, parametrizing the localization properties. One can then follow a similar construction as in [23] to describe Poincaré transformations of the creation and annihilation operators. In particular, one can use the additional degrees

of freedom to “undo the Wigner phase”, so that the phase factor in the Lorentz transformation is independent of the momentum. Then one can construct Poincaré covariant, free fields in the usual manner. The Poincaré covariance determines the two point function which one can calculate explicitly. From this expression it should then be possible to read off the braided commutation relations. Details remain to be worked out [11].

REFERENCES

- [1] ARTIN E. In: LANG S. and TATE J. E. Eds. The collected papers of E. ARTIN. Addison-Wesley, 1965.
- [2] BUCHHOLZ D. and FREDENHAGEN K., Locality and the structure of particle states. *Commun. Math. Phys.*, Vol. **84**, 1982, pp. 1-54.
- [3] DOPLICHER S., HAAG R. and ROBERTS J. E., Local Observables and particle statistics I + II. *Commun. Math. Phys.*, Vol. **23**, 1971, pp. 199-230 and Vol. **35**, 1974, pp. 49-85.
- [4] DOPLICHER S. and ROBERTS J. E., Why there is a Field Algebra with a Compact Gauge Group Describing the Superselection Structure in Particle Physics, *Commun. Math. Phys.*, Vol. **131**, 1990, pp. 51-107.
- [5] FERRARI F., Conformal field theories with nonabelian symmetry group. *Phys. Lett.*, Vol. **B277**, 1992, pp. 423-434, FERRARI F., Multivalued fields on the complex plane and braid group statistics. *Int. Journ. Mod. Phys.*, Vol. **A9**, 1994, pp. 313-326.
- [6] FREDENHAGEN K., On the existence of antiparticles, *Commun. Math. Phys.*, Vol. **79**, 1981, pp. 141-151.
- [7] FREDENHAGEN K., Sum rules for spins in $(2 + 1)$ -dimensional quantum field theory. In: DOEBNER H. D. and HENNIG J. Eds. Quantum Groups. Proceedings, Quantum Group Workshop Clausthal 1989. Lecture Notes in Physics, Vol. **370**, pp. 340-348, Springer 1990.
- [8] FREDENHAGEN K., Generalizations of the theory of superselection sectors. In: KASTLER Ed, The Algebraic Theory of Superselection Sectors, pp. 379-387. World Scientific 1990.
- [9] FREDENHAGEN K., Structure of Superselection Sectors in Low Dimensional Quantum Field Theory. In: CHAU L. L. and NAHM W. Eds., Differential Geometric Methods in Theoretical Physics. Plenum Press 1990.
- [10] FREDENHAGEN K., Global observables in local quantum physics. In: ARAKI H. *et al.* Eds., Quantum and Non-Commutative Analysis, pp. 41-51. Kluwer 1993.
- [11] FREDENHAGEN K. and GABERDIEL, M. R.: in preparation.
- [12] FREDENHAGEN K., GABERDIEL M. R. and RÜGER S. M., Scattering States of Plektons (Particles with Braid Group Statistics) in $2 + 1$ Dimensional Quantum Field Theory. DAMTP-94-90, to appear in *Commun. Math. Phys.*
- [13] FREDENHAGEN K., REHREN K.-H. and SCHROER B., Superselection sectors with braid group statistics and exchange algebras. I: General theory, II: Geometric aspects and conformal covariance. *Commun. Math. Phys.*, Vol. **125**, 1989, pp. 201-226 and *Rev. Math. Phys.*, Special Issue, 1992, pp. 113-157.
- [14] FRÖHLICH J. and GABBIANI F., Braid Statistics in Local Quantum Field Theory, *Rev. Math. Phys.*, Vol. **2**, 1990, pp. 251.
- [15] FRÖHLICH J. and MARCHETTI P. A., Spin-statistics theorem and scattering in planar quantum field theories with braid statistics. *Nucl. Phys.*, Vol. **B356**, 1991, pp. 533-573.
- [16] GUIDO D. and LONGO R., Relativistic invariance and large conjugation in quantum field theory. *Commun. Math. Phys.*, Vol. **148**, 1992, pp. 521-551.
- [17] HAAG R., Quantum field theories with composite particles and asymptotic completeness. *Phys. Rev.*, Vol. **112**, 1958, pp. 669-673; RUELLE D., On the asymptotic condition in quantum field theory. *Helv. Phys. Acta*, Vol. **35**, 1962, pp. 147-163.

- [18] HAAG R., *Local Quantum Physics*. Springer 1992.
- [19] LAUGHLIN R. B., Anomalous Quantum Hall Effect: An Incompressible Quantum Fluid with Fractionally Charged Excitations. *Phys. Rev. Lett.*, Vol. **50**, 1983, pp. 1395-1398; FRÖHLICH J., *et al.*, The fractional quantum Hall effect, Chern-Simons theory, and integral lattices. Preprint, ETH-TH/94-18.
- [20] LEINAAS J. M., MYRHEIM J., On the theory of identical particles. *Il Nuovo Cimento*, Vol. **37B**, 1977, pp. 1-23.
- [21] LONGO R., Index of subfactors and statistics of quantum fields I + II. *Commun. Math. Phys.*, Vol. **126**, 1989, pp. 217-247 and Vol. **130**, 1990, pp. 285-309.
- [22] MACK G. and SCHOMERUS V., Conformal field algebras with quantum symmetry from the theory of superselection sectors, *Commun. Math. Phys.*, Vol. **134**, 1990, pp. 139-196.
- [23] MUND J. and SCHRADER R., Hilbert spaces for nonrelativistic and relativistic 'Free' Plektons (particles with braid group statistics). SFB 288 Preprint No. 74, 1993.
- [24] REED M. and SIMON B., *Methods of modern mathematical physics. III Scattering Theory*. Academic Press 1979.
- [25] REHREN K.-H. and SCHROER B., Einstein causality and Artin braids. *Nucl. Phys.*, Vol. **B312**, 1989, pp. 715-750.
- [26] REHREN K.-H., Field operators for anyons and plektons, *Commun. Math. Phys.*, Vol. **145**, 1992, pp. 123-148.
- [27] ROBERTS J. E., The Statistical Dimension, Conjugation and the Jones Index. To appear in *Rev. Math. Phys.*
- [28] SCHROER B., Scattering properties of anyons and plektons. Presented at the "XXIV Symposium of the theory of elementary particles" in Gosen, Berlin, 1990.
- [29] STEENROD N., *The Topology of Fiber Bundles*, Princeton University Press, 1951.
- [30] SCHRADER R., Notes on Hilbert spaces with braid group statistics. (Unpublished notes 1989).
- [31] TSCHUSCHNER R. D., Topological Spin-Statistics relation in quantum field theory. *Int. Journ. Theor. Phys.*, Vol. **28, 10**, 1989, pp. 1269-1310.
- [32] WILCZEK F., Quantum Mechanics of Fractional-Spin Particles, *Phys. Rev. Lett.*, Vol. **49**, 1982, pp. 957-959.

(Manuscript received May 19, 1995)