

ROBERT CONNELLY

A counterexample to the rigidity conjecture for polyhedra

Publications mathématiques de l'I.H.É.S., tome 47 (1977), p. 333-338

http://www.numdam.org/item?id=PMIHES_1977__47__333_0

© Publications mathématiques de l'I.H.É.S., 1977, tous droits réservés.

L'accès aux archives de la revue « Publications mathématiques de l'I.H.É.S. » (<http://www.ihes.fr/IHES/Publications/Publications.html>) implique l'accord avec les conditions générales d'utilisation (<http://www.numdam.org/conditions>). Toute utilisation commerciale ou impression systématique est constitutive d'une infraction pénale. Toute copie ou impression de ce fichier doit contenir la présente mention de copyright.

NUMDAM

Article numérisé dans le cadre du programme
Numérisation de documents anciens mathématiques
<http://www.numdam.org/>

A COUNTEREXAMPLE TO THE RIGIDITY CONJECTURE FOR POLYHEDRA

by Robert Connelly ⁽¹⁾

1. Introduction.

Are closed surfaces rigid? The conjecture that in fact they all are rigid—at least for polyhedra—has been with us a long time. We propose here to give a counterexample. This is a closed polyhedral surface (topologically a sphere), embedded in three-space, which flexes. (See Gluck [5] for definitions and some references for the history of the problem.)

Certain ambiguities arising from definition 10 of the eleventh book of Euclid's Elements have led many to conjecture the rigidity of closed surfaces. In 1813 Cauchy [2] proved that strictly convex surfaces were rigid, and this result is the basic tool for many other rigidity theorems. Recently Gluck [5] has shown that almost all simply connected closed surfaces are rigid. On the other hand we have shown [3] that there are immersed surfaces which flex. The ideas in [3] are part of the motivation behind the example described here.

The first step is to find an example of an immersed flexible sphere that is not only immersed but has just two singular points in its image. Locally the singular points look like two dihedral surfaces that intersect at just one point in their edges. The next step is to alter the polyhedron only in the neighborhood of these singular points in such a way that the dihedral surfaces flex as before, but one dihedral surface is “crinkled” such that near the intersection point it is pushed in. When this is done the resulting polyhedron still flexes, but the singular points have been erased; no new ones have been created, so it is embedded.

2. A flexible octahedron.

The construction of flexible immersed spheres and the crinkle depend on the flexible octahedra described by Bricard [1] in 1897.

We first describe a flexible octahedron \mathcal{O}_1 that lies in a plane π . As \mathcal{O}_1 flexes it moves out of π , but we are interested at the instant it is in π . Of course \mathcal{O}_1 in this description will be highly singular and will not even be immersed.

⁽¹⁾ Supported by an NSF Grant.

Let $\langle p_1, p_2, p_3 \rangle$ be an equilateral triangle in π . Let it be placed so that the origin is on the perpendicular bisector of p_1, p_2 on the same side as p_3 , outside of the triangle $\langle p_1, p_2, p_3 \rangle$. Let q_1, q_2, q_3 be the reflections of p_1, p_2, p_3 respectively about the origin. Then \mathcal{O}_1 is determined by then taking the cones from p_3 and q_3 over the rectangle p_1, p_2, q_1, q_2 . (See Figure 1.)

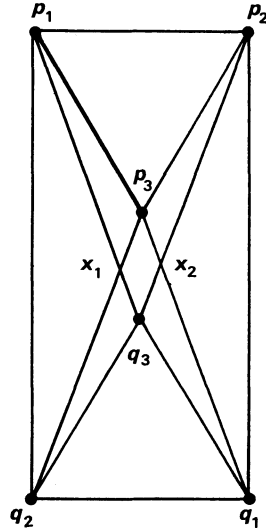

Fig. 1

It is easy to verify that \mathcal{O}_1 is flexible (see Connolly [3], § 4, p. 969). It belongs to the first type discovered by Bricard.

It is easy to check that the disk determined by the cone from p_3 over the quadrilateral p_1, p_2, q_1, q_2 flexes. A simple calculation then shows that the line L through the midpoints of $\langle p_1, q_1 \rangle$ and $\langle p_2, q_2 \rangle$ is perpendicular to $\langle p_1, q_1 \rangle$ and $\langle p_2, q_2 \rangle$, since the quadrilateral has opposite sides equal. Thus if p_3 is reflected through L to q_3 as the p_3 disk is flexed, the quadrilateral is reflected into itself, and thus we get a flex of the whole octahedron.

3. The immersion.

Proposition 1. — *There is a flexible immersed surface, \mathcal{S} , in three-space such that the image of the singular set is a finite number of points (two in fact). In addition these points occur in the interior of 1-simplices of \mathcal{S} .*

Remark. — The above is a variation of [3], and the explicit nature of the proof below is a somewhat easier version.

Proof. — Note that \mathcal{O}_1 constructed in section 2 is topologically two disks mapped on top of each other into the rectangle p_1, p_2, q_1, q_2 . Each disk is made up of four triangles, the cone from p_3 or q_3 over each edge of the rectangle.

Now consider π as being in 3-space, and we shall describe \mathcal{S} , which will be immersed and have only 2 singular points in its image. For the p_3 disk say, let $\langle x, y, z \rangle = \sigma$ be one of its triangles. Find some point $r(\sigma)$, lying on one side of π , lying over the interior of σ . Replace the triangle (2-simplex) σ with the cone from $r(\sigma)$ over the boundary of σ . Do this for each of the 4 triangles of the p_3 disk where $r(\sigma)$ each time is on the same side of π . Next, do the same for the q_3 disk but choosing the cone points on the other side of π . It is easy to see that the resulting surface \mathcal{S} is then immersed with only two singular points in its image. These are the points $\{x_1\} = \langle p_3, q_2 \rangle \cap \langle q_3, p_1 \rangle$ and $\{x_2\} = \langle p_3, q_1 \rangle \cap \langle q_3, p_2 \rangle$.

\mathcal{S} flexes because \mathcal{O}_1 does. Each of the cones over the boundary of a triangle is flexed rigidly. This finishes the proof.

Remarks. — 1) As \mathcal{S} flexes the image of the singular set changes from two points to one circle, but this does not bother us.

2) It is easy to see that by subdividing \mathcal{S} it can be arbitrarily closely approximated by embeddings, but what is not immediate is that any of these approximations will be flexible.

3) There is no way the technique described above (and used more generically in [3]) can be made to yield an embedding. It turns out that for any of the Bricard flexible octahedra, if the 1-skeleton is embedded, the boundaries of some pair of 2-simplices (triangles) topologically link. So there is no way to fill in the holes to get an embedding.

The following is a picture of the local character of a singular point x .

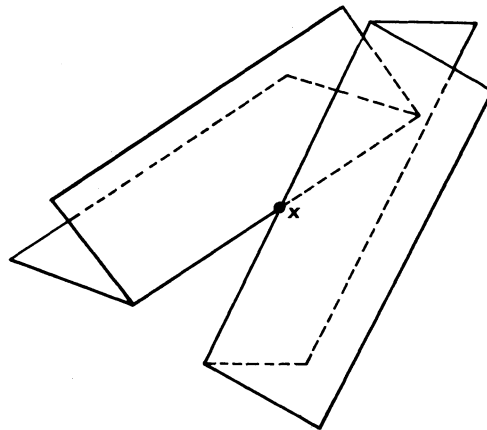

Fig. 2

4. Another flexible octahedron.

Here we describe a special case of the second type of flexible octahedra as defined by Bricard. Let π again be a plane in 3-space. Let C be a circle about the origin with two points p_1 and p_3 on it. Let p_2 and p_4 also be on C such that the directed arc on C from p_1 to p_2 has the same angle as the directed arc from p_3 to p_4 . Note that p_2 can be

chosen as close to p_1 as desired. Let N, S be two points on the line perpendicular to π through the origin (the center of C) equidistant from π on opposite sides. The octahedron \mathcal{O}_2 obtained by coning the self-intersecting quadrilateral p_1, p_3, p_2, p_4 from N and S is flexible. (See Connolly [3], p. 969, § 3.) It retains a symmetry about a plane during its flex. (See Figure 3.)

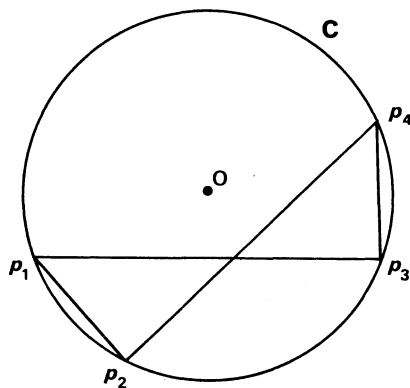

Fig. 3.

5. The crinkle.

Here we regard a dihedral surface as the union of two half-planes that meet along their common edge.

Proposition 2. — Let D be a dihedral surface and x a point on its edge. Let U be any neighborhood of x in 3-space \mathbf{R}^3 . Then there is an embedded flexible polyhedral surface K (the crinkle) that agrees with D outside U , extends the natural flexing of D , and misses any predetermined set F , closed in \mathbf{R}^3 , $F - \{x\} \subset$ one complementary domain of $\mathbf{R}^3 - D$.

Note. — The natural flexing referred to above means the flex obtained by keeping the dihedral surface as a dihedral surface and simply changing the dihedral angle which is not 180° .

In our application F is another dihedral surface meeting D at x .

Proof of Proposition 2. — Let π be a plane bisecting the two half planes of D . Let H be the half plane of π that D projects onto by orthogonal projection. (We assume D is not bent at 180° .) Choose p_1 and p_3 on either side of x close to x along the edge E . Choose O in H along the perpendicular bisector of p_1, p_3 close to E . Let N, S be the points on D that project onto O . If O is close to E , then N, S , are also in U . Next consider the circle C in π with center at O through p_1 and p_3 . Choose p_2 on C outside H and close to p_1 , and let p_3 be as before. Choose p_4 on C , inside H , so that the length of $\langle p_1, p_2 \rangle$ is the same as $\langle p_3, p_4 \rangle$.

As in Section 4, N, S, p_1, p_2, p_3, p_4 determine a flexible octahedron. However, we shall define a slightly different surface. Let

$$Z = (E - \langle p_1, p_3 \rangle) \cup \langle p_1, p_2 \rangle \cup \langle p_2, p_4 \rangle \cup \langle p_4, p_3 \rangle.$$

Let the image of K be $(D - (\{N, S\} * \langle p_1, p_3 \rangle)) \cup (\{N, S\} * Z)$ ($A * B$ denotes the join of A and B , the set of all line segments from A to B).

Clearly K flexes as D does on the overlap, since p_1 and p_3 need only be kept at a fixed distance, and D takes the place of $\langle p_1, p_3 \rangle$ in \mathcal{O}_2 . Since topologically Z is an embedded line, the suspension (the join from N and S) will be embedded also. So K is embedded.

If $F - \{x\}$ is not on the same side of D as H , then slide K over until x is near p_3 . If p_2 is close to p_1 , K will miss F . If $F - \{x\}$ is on the same side as H , slide K over until p_1 is near x and K will miss F again. Clearly all the above alterations to D can be done close enough to x so that K will agree with D outside U . This completes the proof.

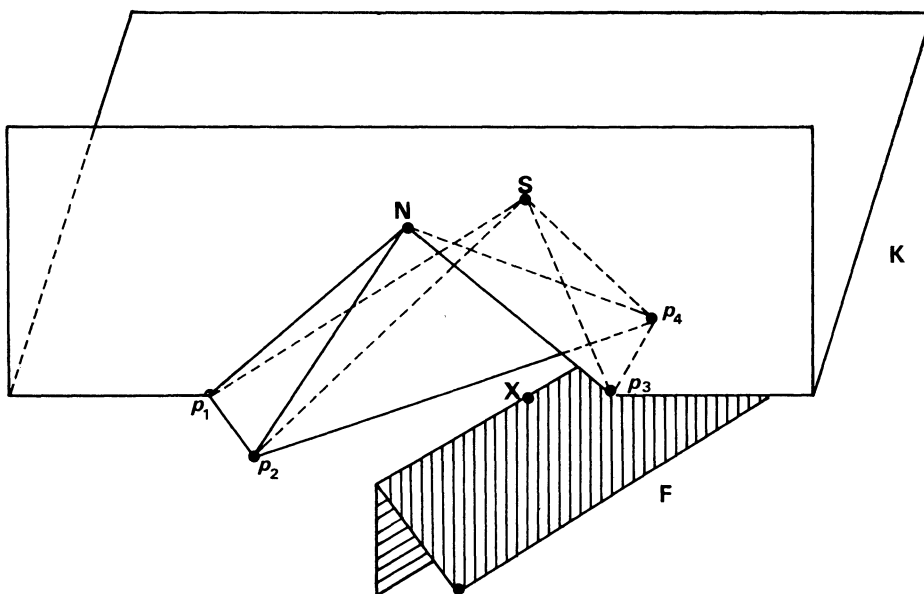

Fig. 4

6. The example.

Theorem. — *There is a flexible embedded surface.*

Proof. — Let \mathcal{S} be a surface as in the conclusion of Proposition 1. I.e. \mathcal{S} has only a finite number of points x_1, \dots, x_n as the image of a singular set, and locally near each x_i \mathcal{S} looks like two dihedral surfaces meeting at one point as in Figure 2. We apply Proposition 2 n times at these points, where U_i is some small neighborhood at x_i ; in the complement of the simplices that miss x_i , F_i is one dihedral surface near x_i , and $D = D_i$ is the other. The final crinkled surface is embedded and flexes as \mathcal{S} does. *Done.*

Remark. — It is easy to check that both \mathcal{O}_1 and \mathcal{O}_2 define “o” volume (see Connolly [4] for the notion of generalized volume and the proof that flexible suspensions have o

generalized volume). Thus \mathcal{S} and the crinkled \mathcal{S} in the final example both have constant volume (>0) as they flex. In other words if one were to pour water into the interior of one of these examples it would still flex. It still is an open question as to whether all such flexible surfaces (embedded or not) preserve (generalized) volume.

In higher dimensions the question of whether there is a closed polyhedral $n-1$ dimensional surface which is flexible in n -space is still unknown for $n \geq 4$.

N. H. Kuiper also has pointed out that the problem of the existence of flexing C^2 -isometrically embedded 2-spheres or other surfaces in 3-space remains open. Recall, however, that in the category of C^1 -isometric embeddings, the flexibility seems about as large as the differentiable (non-isometric) flexibility by the work of Kuiper [6] following Nash.

The author thanks the Institute des Hautes Études Scientifiques and Dennis Sullivan very much for their steadfast support and encouragement while he was working on this and related problems. It is greatly appreciated.

RÉFÉRENCES

- [1] R. BRIGARD, Mémoire sur la théorie de l'octaèdre articulé, *J. Math. Pures Appl.* (5), **3** (1897), 113-148.
- [2] A. L. CAUCHY, Sur les polygones et polyèdres, Second Mémoire, *J. École Polytechnique*, **19** (1813), 87-98.
- [3] R. CONNELLY, An immersed polyhedral surface which flexes, *Indiana University Math. J.*, **25** (1976), 965-972.
- [4] R. CONNELLY, The rigidity of suspensions, to appear in the *Journal of Differential Topology*.
- [5] H. GLUCK, Almost all simply connected closed surfaces are rigid, *Lecture Notes in Math.* 438, *Geometric Topology*, Springer-Verlag (1975), 225-239.
- [6] N. H. KUIPER, On C^1 -isometric imbeddings, *Indag. Math.* XVII (1954), 545-556 and 683-689.